



WWW.DYNAMICMIXERS.COM



5 gal.  
3 / 5 heads of lettuce

## ADVANTAGES

- More hygienic thanks to its sealed cover: no water or bacteria retention.
- **HACCP** method: *Hazard Analysis Critical Control Point*
- Certified to NSF / ANSI 2-2009: North American Health standard certifying that the product meets strict requirements of quality and safety.
- Fast and efficient, it respects the product's fragility.
- Heavy duty construction for an intensive daily use.

## USE

Indispensable to prepare high volume of salads.  
Capacity: 20 litres / 5 gal.  
Recommended for 3 or 5 heads of lettuce



**E20SC - 20L**

Ref. E004



## TECHNICAL DATA

<b>DIAMETER</b>	<b>430 mm / 16.9"</b>
<b>TOTAL HEIGHT</b>	<b>500 mm</b>
<b>ACTUAL WEIGHT - SHIPPING WEIGHT</b>	<b>3.6 kg / 7.9 lbs - 4.8 kg / 10.5 lbs</b>

Outside container, top and inner basket in Polypropylene (*Food-safe plastic*).

Aluminum handle.

## MAINTENANCE

To clean, simply remove the top and inner basket from the outside container. Wash all three components thoroughly with a mild liquid soap. Rinse with hot water as to remove all soap residues.

**Do not put in a dishwasher.**



# TECHNICAL SHEET

## MANUAL SALAD SPINNER E 20 "SEALED COVER"

Parts list	Code
Waterproof seal 14 x 24 x 7	0644
Waterproof seal 25 x 27 x 6	0645
O. Ring	0646
Screws TBF 3.9 x 14	079958
Outside basket	2801
Perforated drive gear + pin	2806
Large gear	2807
Small gear	2808
Axle for outside basket	2810
Pin for large gear	2811
Axle for drive & small gear	2813
Axle	2814
Set of gears (2806, 2807, 2808, 2811, 2822)	2815.2
Handle only	2820
Small cover (w/ o handle & drive gear)	2821
Output small gear	2822
Equipped cover (O. Ring + Waterproof seal)	2823
Coupling sleeve	2824
Inside basket	2825
Small cover with handle & gear	2826
Complete cover	2827
Plate + screws (3)	2828
Screws (4)	9014

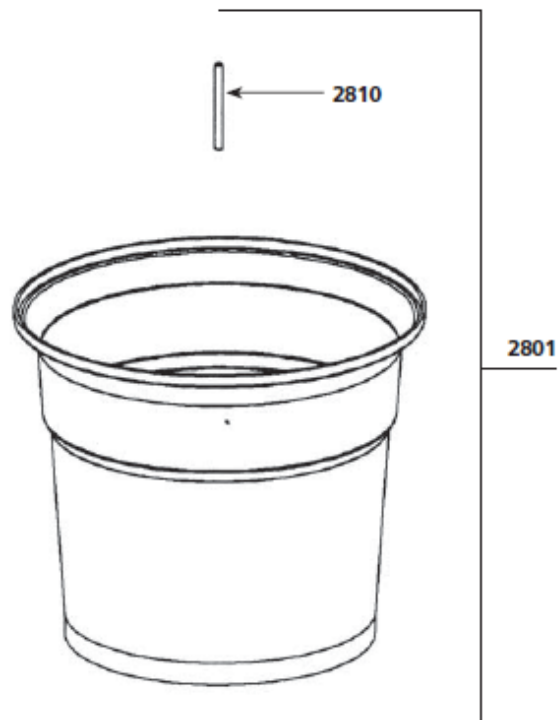
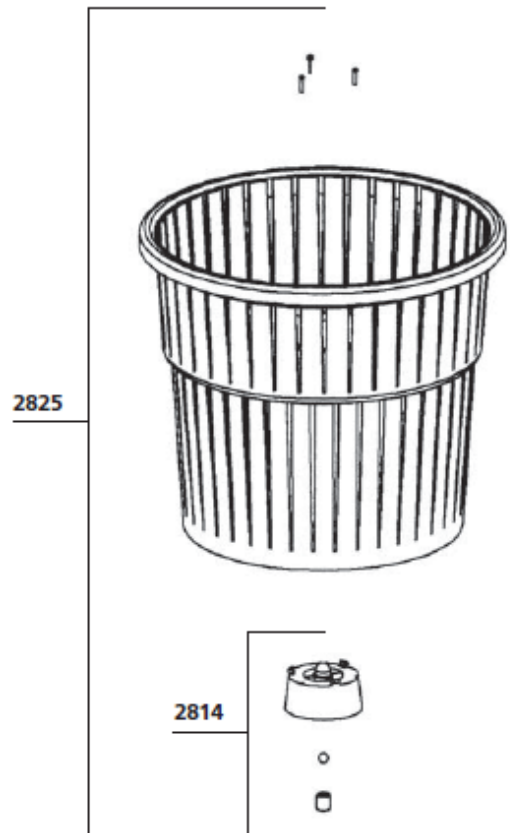

2827

2826

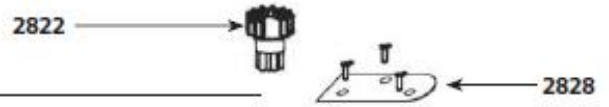
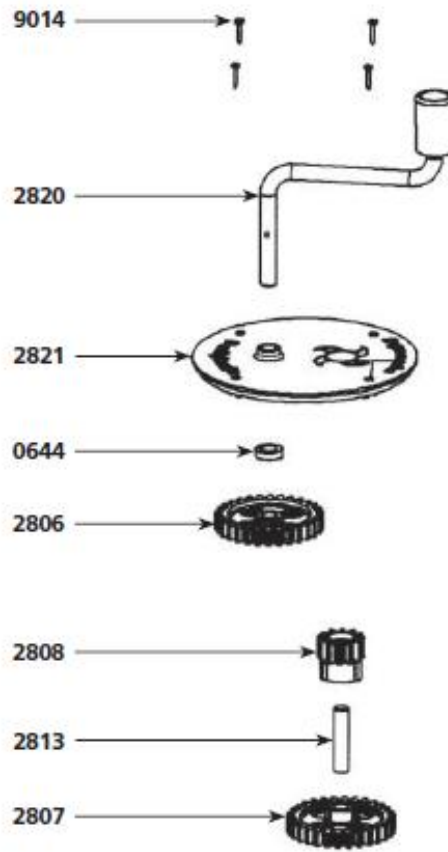

2823

