

Automatic rack-type dishwasher, capacity up to 200 racks, 3.600 plates or 7.200 glasses per hour



Machine shown with optional CDC-90 degree corner dryer

Product Advantages:

- Single rinse system - 200 l/h - (1.5 / 1.0 litres per rack)
- "E"-pre-wash with removable scrap tray
- Stainless steel tank cover strainer system
- Optimum hygiene safety - deep drawn tank
- Two speed - 135 / 200 racks / hr
- Double skin insulated full width spring assisted door
- Optional heat recovery for lower operating costs
- Stainless steel 1.5kW wash pump
- Including main switch and emergency stop
- Drop-In wash arms with no end caps
- Colour-coded cleaning assistance

Connections mirrorwise for R/L working direction

Machine shown with optional D-90-20 dryer.

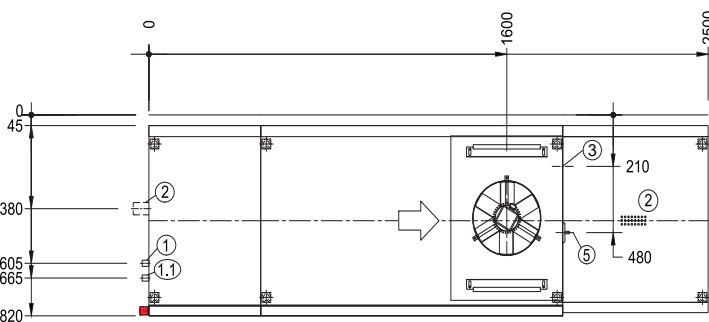
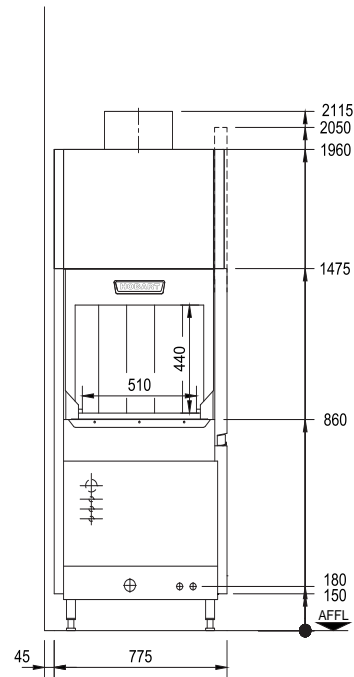
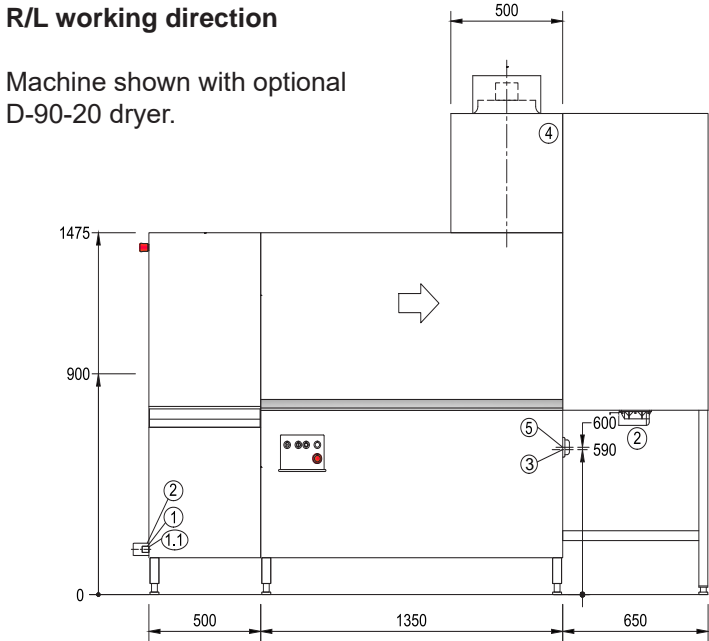

1	Warm water connection (filling)	R 3/4" 0 - 3°d, (1,4mmol/l); 55-65 degrees Celcius
1.1	For machine operation	Warm water connection for machine without heat recovery Cold & Warm water connection for machine with heat recovery
		R 3/4" 0 - 3°d, (1,4mmol/l); max. 200 l/h; demineralized water blended to have appr. 80 µs/cm
2	Drain	DN 50
3	Power supply	415/50/3 N+E Without dryer - 26.9kW / With dryer (D90) - 30.5kW
4	Exhaust	approx. 280m³/hr
5	Main switch	
Table height 900mm Machine height +/- 25mm feet adjustable		

BASIC MODEL

- Automatic rack type dishwasher
- Two speed
- Nominal capacity of 135/200 racks/h or 3,600 plates/h or 7,200 glasses/h
- Electrical load 415/50/3N+E
- Warm water connection - maximum 200litres per hour consumption
- Deep drawn tank, strainer pan, frame, wash arms, rinse arm and panels are stainless steel 1.4301
- Includes main switch and emergency stop switch
- Optional heat recovery - hot and cold water connections required
- Dishracks sold separately

ORDER NO.	DESCRIPTION	\$ ex GST
CSEA-90-20-R/L	Right to Left Feed CSEA-90-20	P.O.A.-
CSEA-90-20-L/R	Left to Right Feed CSEA-90-20	P.O.A.-

OPTIONAL EQUIPMENT

ORDER NO.	DESCRIPTION	\$ ex GST
SEF-19/011	C12 - Heat recovery for CS models	P.O.A.-
D-90-20	CS Series dryer - adds 3.6kW to machine - multi directional	P.O.A.-
CDC-90-15-L/R	Left to right feed 90 degree corner dryer - adds 5.1kW to machine	P.O.A.-
CDC-90-15-R/L	Right to left feed 90 degree corner dryer - adds 5.1kW to machine	P.O.A.-
CAF-700-L/R	Left to right feed 700mm corner angle feed	P.O.A.-
CAF-700-R/L	Right to left feed 700mm corner angle feed	P.O.A.-
CAF-900-L/R	Left to right feed 900mm corner angle feed	P.O.A.-
CAF-900-R/L	Right to left feed 900mm corner angle feed	P.O.A.-
CTC-90-L/R	Left to right feed 90 degree powered corner entry / exit curve	P.O.A.-
CTC-90-R/L	Right to left feed 90 degree powered corner entry / exit curve	P.O.A.-
04-001050-5	Photo cell end stop switch - suits HOBART roller tables	P.O.A.-
01-249750-4	Mechanical end stop switch	P.O.A.-
SE-H+IS2	Economy Single Cartridge water softener with IS2 install kit - per water inlet	P.O.A.-
SD-H+IS2	High Capacity Dual Cartridge water softener with IS2 install kit - per water inlet	P.O.A.-
	For dishracks refer to DISHRACK CHAPTER	
	For entry and exit tables & conveyors refer to TABLING CHAPTER	