



Catalogue :

SERIE 900 KORE

Chapter :

PASTA COOKERS 900 KORE

Article :

CP-G910 LPG 230V 1N

Code:

19036952

<u>DIMENSIONS AND WEIGHTS</u>		<u>Net dimensions</u>	<u>Packed</u>
Length	mm	800,00	1.022,00
Depth	mm	930,00	840,00
Height	mm	850,00	1.265,00
Weight	kg	109,00	129,00
Volume	m3	0,78	1,09
<u>ELECTRICITY</u>		230V	50/60Hz
	Power		0,10 kW
Connections	230 V. 1+N+T	2X1,5+T - 2 A	
	230 V. III+T	3X1,5+T - 6 A	
	400 V. III+N+T	4X4+T -32A	
<u>GAS</u>	Power		32,00 kW
	Gas type	LPG	
	Consumption		2,52 kg/h
	Pressure	LPG G30/G31 28-30/37 mbar	
<u>WATER</u>	Pressure	Water Pres:200-400kPa(2-4bar)	
<u>STEAM</u>	Not necessary		
<u>AIR</u>	Not necessary		

DESCRIPTION

GAS PASTA COOKERS, CP-G910

Pasta cookers are devices specially designed to boil pasta, and they can also be used to boil vegetables, rice or eggs.

They are used with specific baskets in different sizes and volumes (1/1 or fractions 1/2 - 1/3 - 1/4 - 1/6).

2 mm stainless AISI-304 steel top with rounded edges for easy cleaning.

Laser cut and automatic welding for a perfect adjustment of sides between modules with square angle finish.

Number of wells: 2.

Standard equipment: Three 1/3 baskets by well.

2 x 40 liters water basins. They can be used with different combinations of basket sizes.

Integrated 1.5 mm AISI-316-L stainless steel basin with rounded edges for easy cleaning.

Electrical filling valve with two position switch: fast and medium filling speed. Basin discharge manual tap highly resistant to high temperature and safety overflow.

Stainless steel burner outside the pan with combustion chamber that allows heating the bottom and side walls.

Electronic ignition. Access tube for manual ignition.

Safety valve tap to control heating.

Low water level automatic safety shut off.

Provided with integrated drip zones on which baskets can be placed for draining purposes.

Water-tight and protecting-support controls.

High temperature protector for the chimney made of enamelled cast iron.

Front access to components.

According to European standards for components and panels temperature, efficiencies and combustion, and sanitary regulations (EN-60335 and EN-203)

IPX5 grade water protection equipment.

Maximum power: 33.0 kW - Gas

It requires an 230V - 1+N power supply.

Dimensions: 800 x 930 x 850 mm.

SOUND LEVEL < **65,00 db**

CERTIFICATES **1312CR6172**

<u>INSTALLATION - CONNECTIONS</u>	<u>Ø</u>
▶ ELECTRICITY	SI
▶ COLD WATER	"1/2""
▶ DRAIN	30X25
▶ DRAIN	30X25
▶ COLD WATER	1/2"
▶ GAS	"R.3/4""G"
▶ GAS	R.3/4"G"





Catalogue :

SERIE 900 KORE

Chapter :

PASTA COOKERS 900 KORE

Article :

CP-G910 LPG 230V 1N

Code :

19036952

SCHEMA - DIMENSIONS

CP-G910

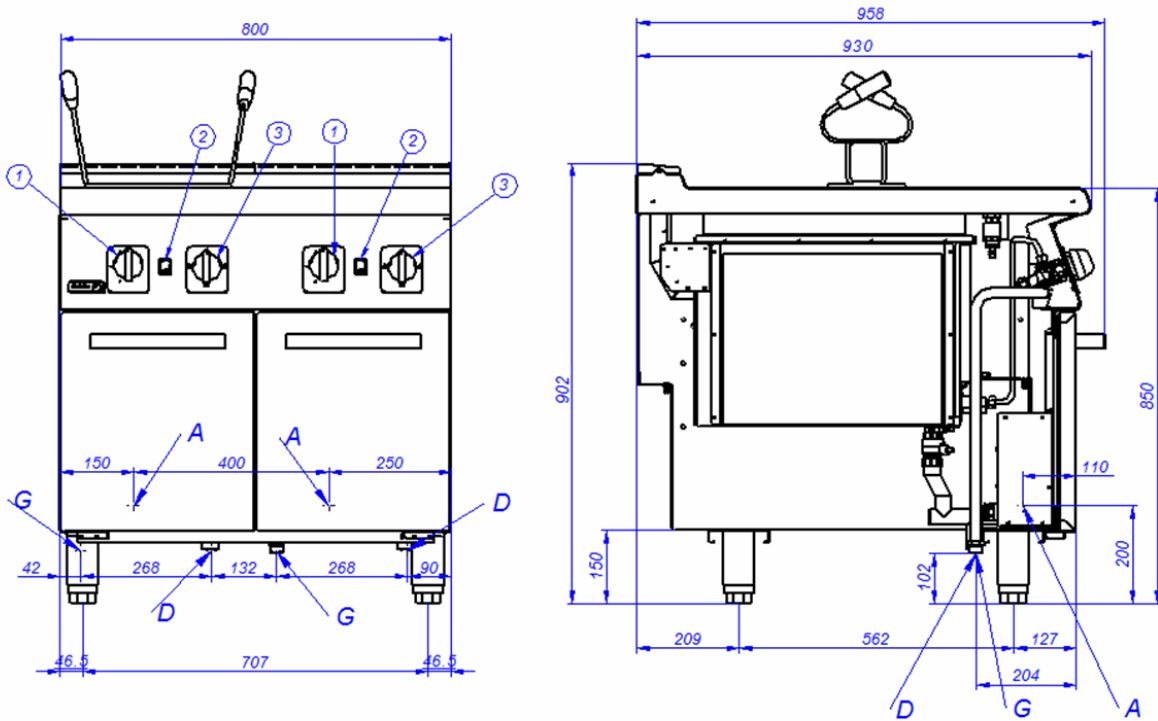

- A – Entrada de Agua
- G – Entrada de Gas
- D – Desagüe
- 1 – Grifo válvula de gas
- 2 – Pulsador tren de chispas
- 3 – Grifo de entrada de agua

- Water Inlet
- Gas Inlet
- Drainage
- Gas valve tap
- Piezoelectric ignitor
- Water inlet tap