

HEATED REGENERATION CABINETS/BANQUET CARTS

- Gently brings foods back to desired serving temperature
- Even convection heating
- Designed to be easily cleaned
- Built in water tray to increase humidity
- Adjustable temp. control
- Solid S/S doors
- Temperature gauge
- Low energy use design
- Castors
- Temperature range 50 - 110°C

DH-11-5FE

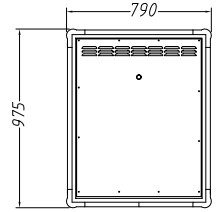
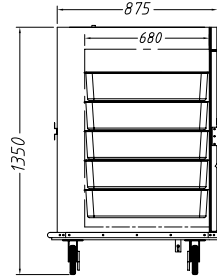
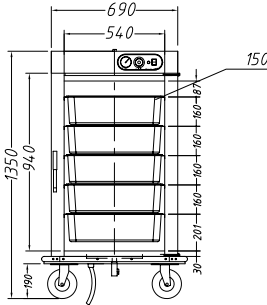

DH-11-21SE

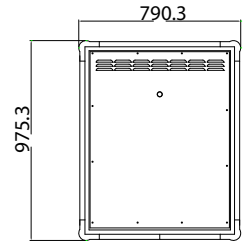
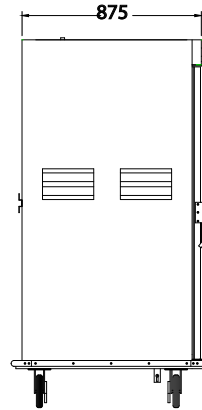
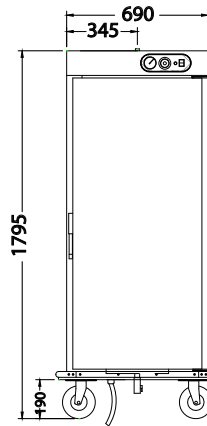

DH-22-21DE

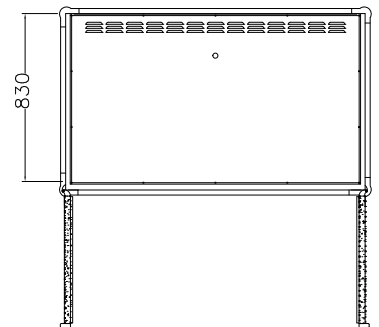
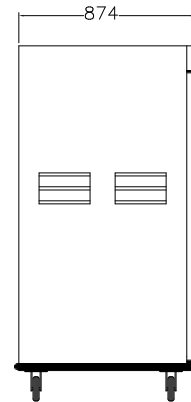
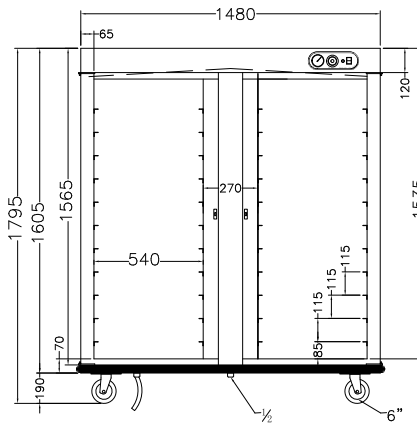

Code	Dimensions (WxDxH mm)	Weight (kg)	Temperature Range °C	Voltage	Power (kW/A)
Medium Single Banquet Cart - 5 runners with 160mm spacing – 5x2/1 GN pan or 10x 1/1 GN pan					
DH-11-5FE	790x975x1350	136	+50 to +110	240	2.62/15
Large Single Banquet Cart - 11 runners with 110mm spacing – 11x2/1 GN pan or 22x 1/1 GN pan					
DH-11-21SE	796x980x1795	182	+50 to +110	240	2.62/15
Large Double Banquet Cart - 22 runners with 110mm spacing – 22x2/1 GN pan or 44x 1/1 GN pan					
DH-22-21DE	1540x980x1795	360	+50 to +110	240	2.62/15

Heated units are for hot food holding only, not designed to heat product. Prices and specifications are subject to change without notice. Pictures are for illustrative purpose and final product may differ