

**CONVECTION OVENS**

- Stainless steel cooking chamber with rounded corners
- Tempered low-e glass
- Door overture with fan/s stop systems
- LED alarms
- Interlocking gasket fixing system
- According to IPX3 standard norms
- High resistance hinge
- Temperature range of 50°C - 280°C
- 60 minute timer or infinite
- 84mm distance between trays

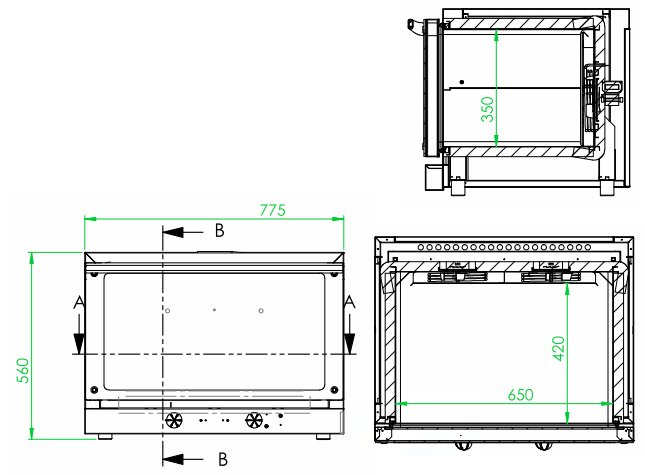
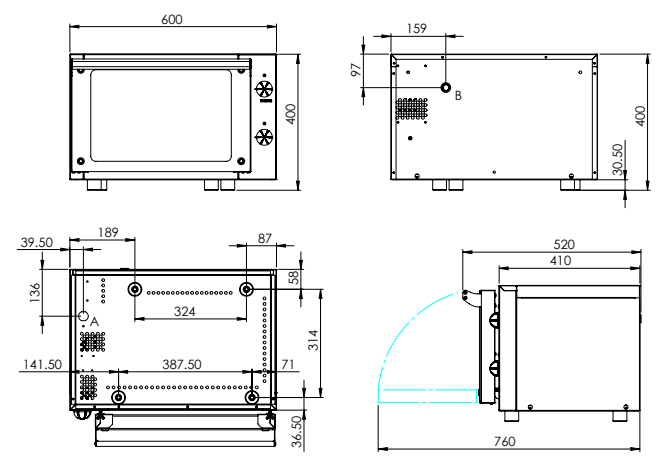

Code	Trays*	External Dimensions (WxDxH mm)	Internal Dimensions (WxDxH mm)	Weight (kg)	Voltage	Power (kW/A)
<b>Convection Oven</b>						
TDE-3B	3 x 600x400mm	775x700x560	650x460x350	36	240	3.1/15
TD-3NE	3 x 2/3GN	600x520x390	400x370x250	25	240	2.8/15

\*Pans & trays not included. • Warranty will be void if the correct type of water filtration system is not installed & in use. It requires a Tundish installed correctly at the drainage connection point. Prices and specifications are subject to change without notice. Pictures are for illustrative purpose and final product may differ.