

FAGOR GAS KORE 900 SERIES

PASTA / NOODLE COOKER

- 2mm thick AISI-304 stainless steel cooktops
- Heating controlled through safety valve
- Detachable draining rack at the front for baskets
- Machine with IPX5 grade water protection
- Detachable draining rack at the front for baskets

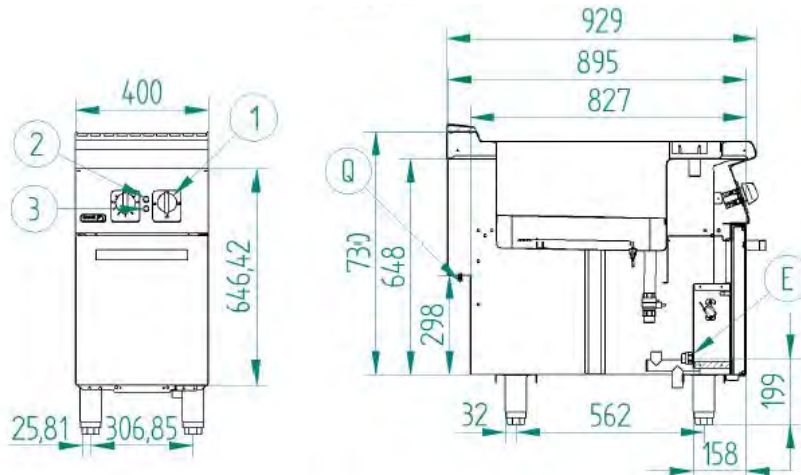

- E - Electrical connection
- Q - Equipotencial connection
- 1 - Thermostat control
- 2 - Green pilot
- 3 - Ambar pilot

| Code | Gas Type | Baskets | Capacity x Tank | Dimensions (WxDxH mm) | Weight (kg) | Regulator Size | Consumption (MJ/h) | kW |
|---------|----------------------------|------------|-----------------|-----------------------|-------------|----------------|--------------------|----|
| CP-G905 | NG or LPG (please specify) | 3 x 1/3 GN | 40L x 1 | 400x930x850 | 70 | 3/4" | 57.6 | 16 |

• All 900 Series cooking equipment is supplied to suit Natural Gas connections but can be converted to suit LPG connections on request. Prices and specifications are subject to change without notice. Pictures are for illustrative purpose and final product may differ