

ASIAN RANGE – HEAVY DUTY S/S WATERLESS GAS WOKS

- Cast iron wok rings, anti-leak around the rings
- 14" Heavy duty cast iron wok rings
- Stainless steel exterior
- Removable drip tray and front gutter for ease
- High heat output
- Standard with flame failure and pilot light
- Extra high splash back with spice shelf mechanically attached
- Flat front panel for valve control by knee-push or hand turn action
- Front gutter designed for easy clean and maintenance
- Duckbill jet burners included, Chimney burners installed on request

WW-1N / WW-1L

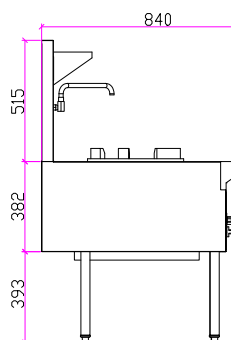
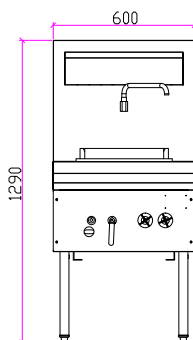

WW-2N / WW-2L

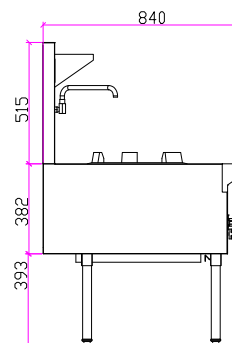
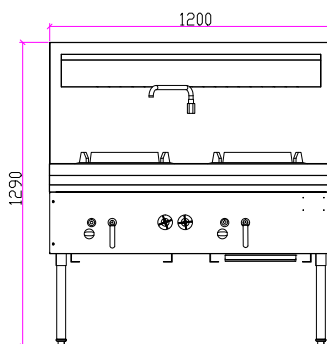

WW-3N / WW-3L

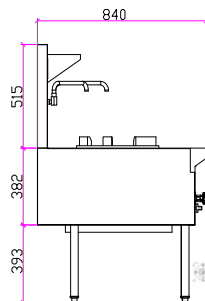
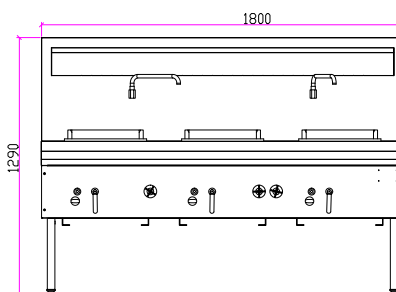

Code	Gas Type	Dimensions (WxDxH mm)	Weight (kg)	Regulator Size	Duckbill (MJ/h)	Chimney (MJ/h)
1 Burner						
WW-1N	NG	600x850x1300	65	3/4"	120	130
WW-1L	LPG	600x850x1300	65	3/4"	110	115
2 Burners						
WW-2N	NG	1200x850x1300	120	2x 3/4"	240	260
WW-2L	LPG	1200x850x1300	120	2x 3/4"	220	230
3 Burners						
WW-3N	NG	1800x850x1300	175	3x 3/4"	360	390
WW-3L	LPG	1800x850x1300	175	3x 3/4"	330	345

Tapware and its installation is not included, contact FED Service for pricing.

• Gas equipment must be commissioned by an authorised technician.

Prices and specifications are subject to change without notice. Pictures are for illustrative purpose and final product may differ