

650 SERIES EQUIPMENT



Example of optional bench stand shown on FlexiDrawer Counter Fridges CRB1-2 + CRB-1-3

• Gas equipment must be commissioned by an authorised technician.
Prices and specifications are subject to change without notice. Pictures are for illustrative purpose and final product may differ

650 SERIES - STAINLESS STEEL STANDS



JUS300E

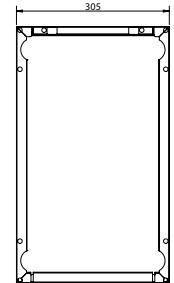
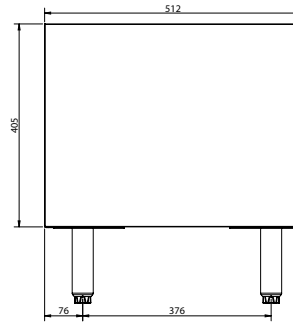
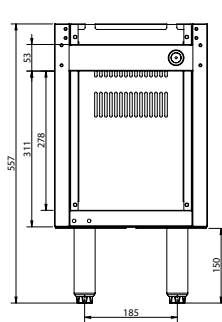
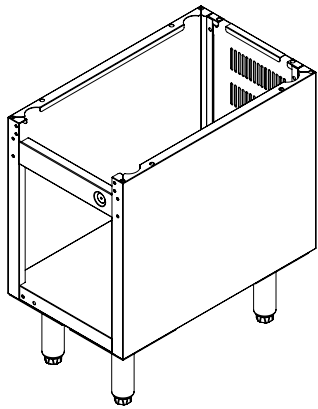

JUS400E

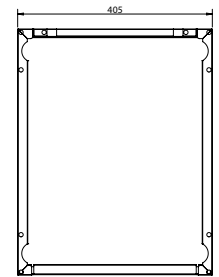
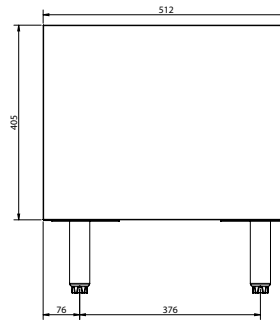
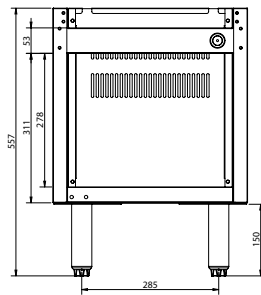
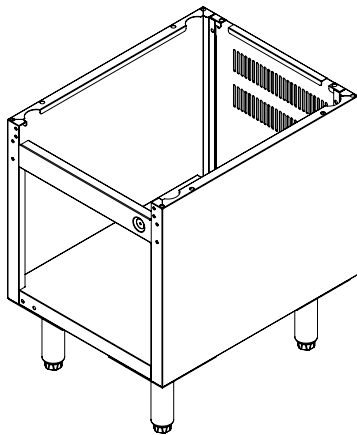

JUS600E

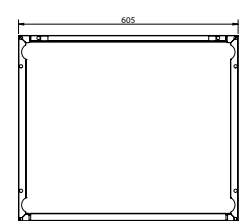
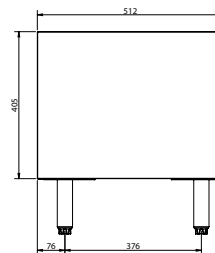
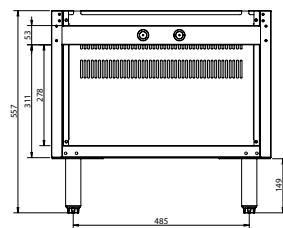
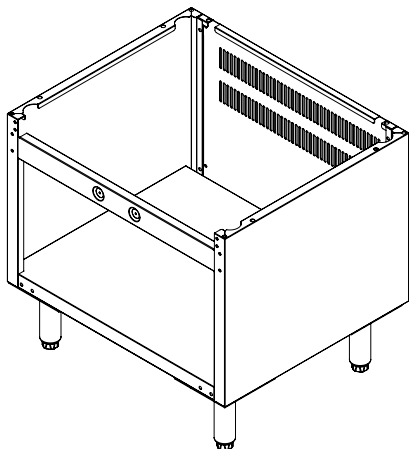

Code	Gas Type	Description	Dimensions (WxDxH mm)	Weight (kg)
JUS300E	-	Cabinet for JUS-TR-2B	305x512x557	11
JUS400E	-	Cabinet for JUS-TRC-1	405x512x557	13
JUS600E	-	Cabinet for JUS-TR-4B & JUS-TRC-2	605x512x557	15.5

Prices and specifications are subject to change without notice. Pictures are for illustrative purpose and final product may differ