

CONCEPT MODULAR DISHWASHER

- Prewash module with 3 upper and 3 lower washing branches
- High-power washing system with 5 upper and 5 lower washing branches
- 3 washing programs: intensive (90 baskets/hr), medium (135 baskets/hr), high capacity (180 baskets/hr)
- Double effect rinse and pre-rinse
- Comes with 2 base baskets, 2 baskets for plates, 1 basket for cutlery

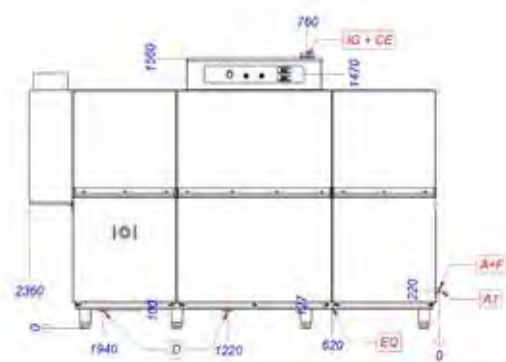

NEW PRODUCT

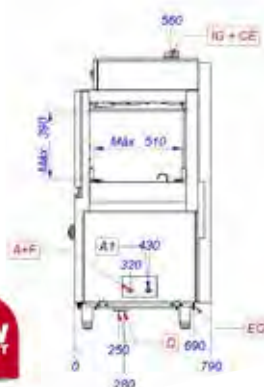

CCO-225DCW

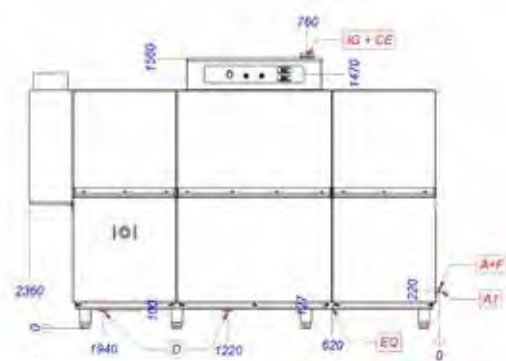
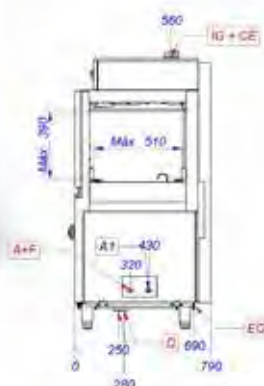

CCO-225ICW

AS-260	Anti-splash guard supplement
LP	Main wash
DA	Double effect rinse and pre-rinse
PL3	Cold water prewash

A+F	Water inlet & filter
CE	Power supply
D	Drain
EQ	Equipotential bonding terminal
IG	General Switch

Code	Modules Consumption	Dimensions (WxDxH mm)	Weight (kg)	Voltage/Hz	Power (kW/A)
Right hand side entrance					
CCO-225DCW	AS-260 + PL3 + LP + DA	2360x790x1560	381	415/50	45/3~N
Left hand side entrance					
CCO-225ICW	AS-260 + PL3 + LP + DA	2360x790x1560	381	415/50	45/3~N

RACK CONVEYER DISHWASHERS SINK BENCHES

- Corner sink bench with introductory of baskets in corner
- Wide range of entry / exit and prewashing tables
- Designed for 500 x 500 mm dishwashing baskets
- Quick installation and easy connection to the dishwasher.
- No holes on the surface
- AISI-304 stainless steel (18/10).
- 40 x 40 mm square tubular adjustable legs in AISI-304 stainless,
- Deep anti-drip profiles completely folded with lower edge for safe and easy cleaning
- Angle table prepared to connect the basket loader to the dishwasher
- Element to introduce the baskets with the movement of the advancement system of the conveyer
- Rear guard 200 mm
- Flexible shower tap

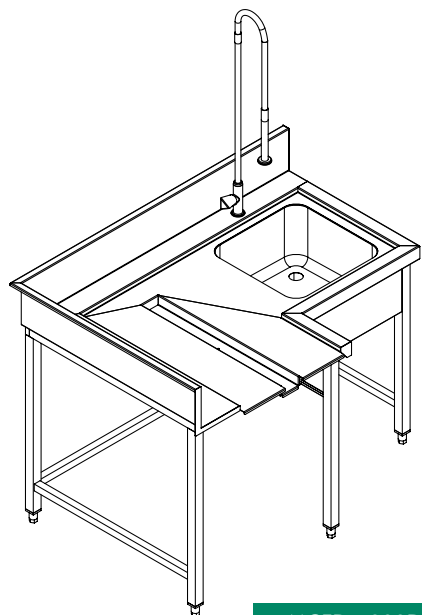

MCFD-1000D

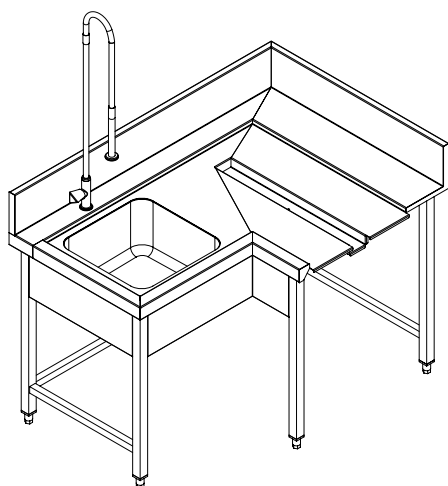
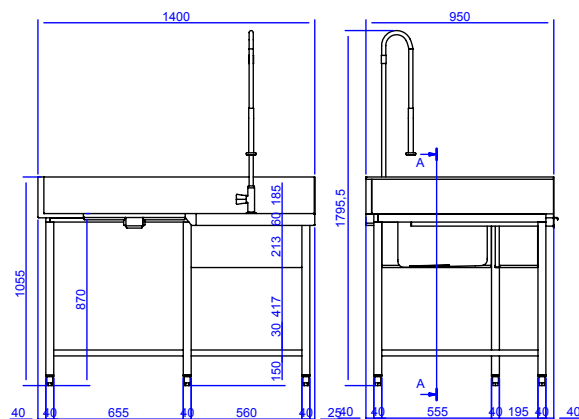
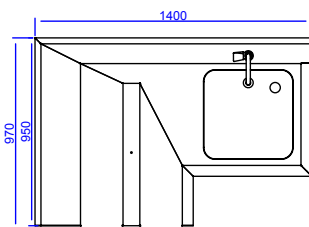

MCFD-1000I

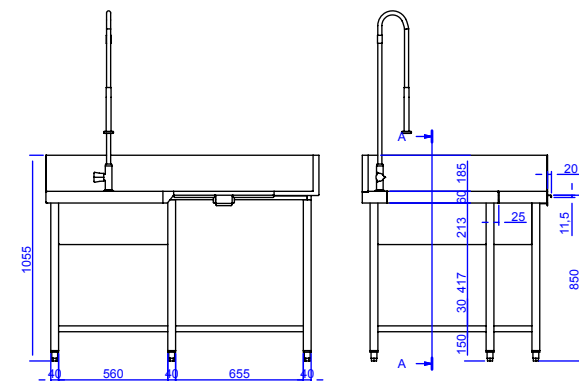
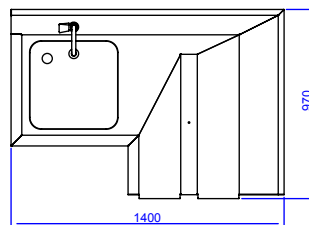

Code	Sink Dimensions (WxD mm)	Sink Area (WxD mm)	Loader Area (WxD mm)	Dimensions (WxDxH mm)	Weight (kg)
To be placed at right					
MCFD-1000D	450x450	1400x700	950x800	1450x1000x900	80
To be placed at left					
MCFD-1000I	450x450	1400x700	950x800	1660x630x870	80

Prices and specifications are subject to change without notice. Pictures are for illustrative purpose and final product may differ

DRYING TUNNEL

- TS-COO specially for modular models 180 and 225
- Supplementary element with 9kW heating element box and upper fan for drying off the dishes with 0.55kW motor
- TS8-COO specially for modular models 320
- Supplementary element with 13.5kW heating element box and upper fan for drying off the dishes with 1.1kW motor
- Module with conveyance system included, for placement at the end of the machine
- With separator curtains
- Bottom shelf

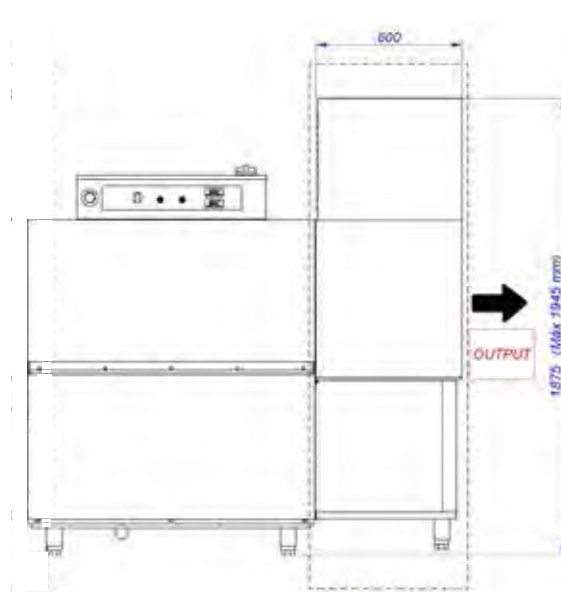
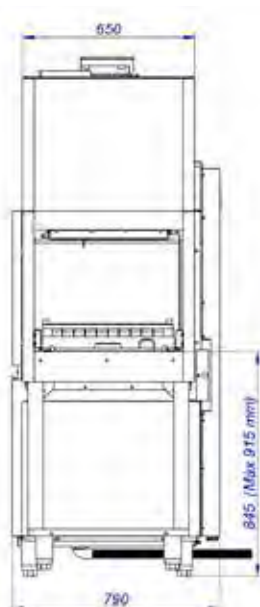

TS-COO

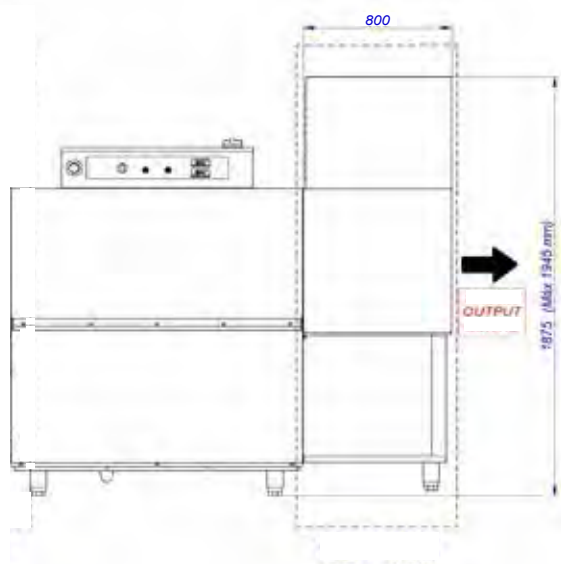
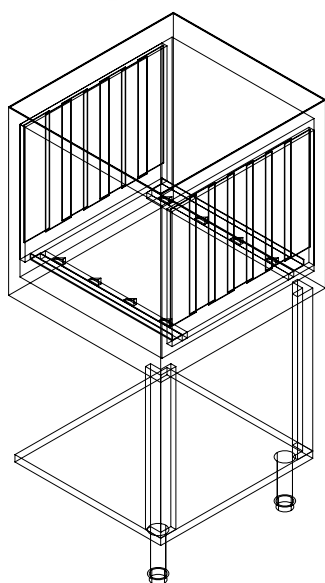

TS8-COO

Code	Dimensions (WxDxH mm)	Weight (kg)	Voltage/Hz	Power (kW/A)
Drying Tunnel				
TS-COO	600x790x1930	70	415/50	9.55/3~N
TS8-COO	800x790x1930	110	415/50	14.8/3~N

Prices and specifications are subject to change without notice. Pictures are for illustrative purpose and final product may differ

CORNER BENCH WITH INTRODUCTION OF BASKETS

- Introduce baskets with advancement conveyor system
- Introducer of baskets 90° by the right / left side for with anti-splash at the entry
- Wide range of entry / exit and prewashing tables
- Designed for 500 x 500 mm dishwashing baskets
- Quick installation and easy connection to the dishwasher.
- No holes on the surface
- AISI-304 stainless steel (18/10).
- 40 x 40 mm square tubular adjustable legs in AISI-304 stainless,
- Deep anti-drip profiles completely folded with lower edge for safe and easy cleaning
- Element for coupling at an angle to the inlet of the dishwasher drag, and insert the baskets automatically
- The drag nails are activated by the drag mechanism of the dishwasher
- Provided with lower shelf

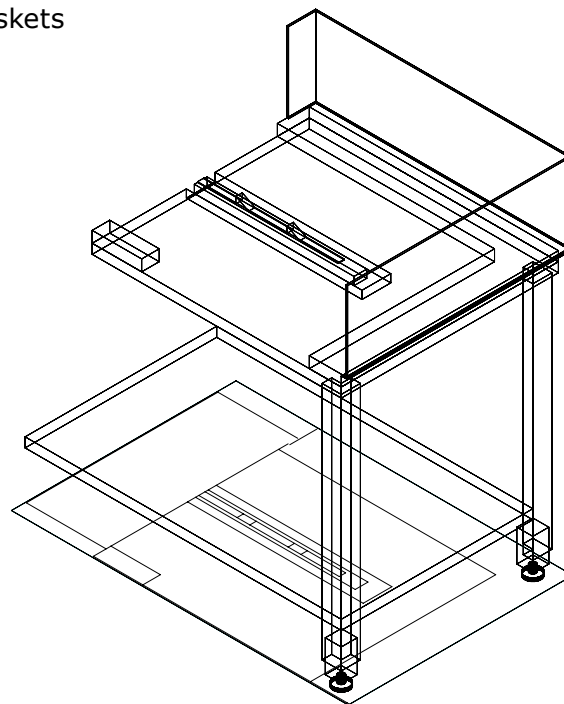

Code	Dimensions (WxDxH mm)	Weight (kg)
By the right side		
E-90D	790x690x850	15
By the left side		
E-90I	790x690x850	15

ROLLING TABLES

- Wide range of entry / exit and prewashing tables
- Designed for 500 x 500 mm dishwashing baskets
- Quick installation and easy connection to the dishwasher
- No holes on the surface
- AISI-304 stainless steel (18/10).
- 40 x 40 mm square tubular adjustable legs in AISI-304 stainless
- Deep anti-drip profiles completely folded with lower edge for safe and easy cleaning
- Automatic movement with the conveyor exit

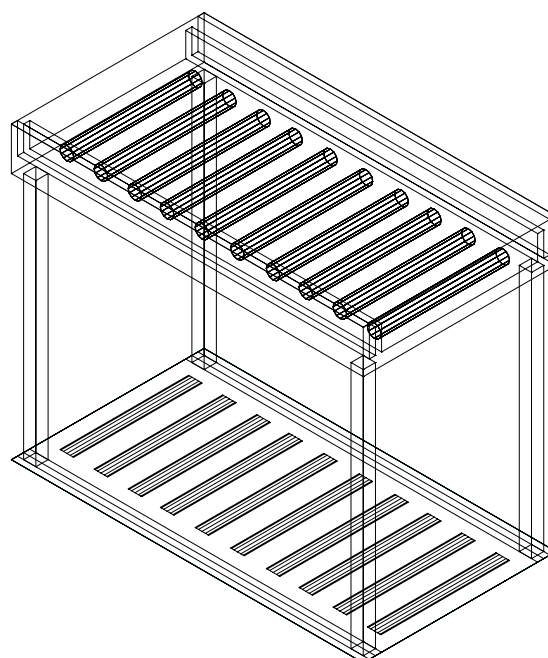

Code	Dimensions (WxDxH mm)	Capacity (Baskets)
MR2C	1150x630x870	2
MR3C	1660x630x870	3
MR4C	2170x630x870	4

Prices and specifications are subject to change without notice. Pictures are for illustrative purpose and final product may differ