

CHEWBLET / NUGGET ICE MACHINE

- Simple maintenance and easy to move, modular design
- Excellent electric control system
- AIR-COOLED
- Fully automatic and accurate control system
- U.S. Morrill Water Pump
- German ĘBM-Pabst fans
- Hisakage PCL
- Denmark Danfross Expansion
- Valve & Dry Filter
- Japanese Saginomiya Solenoid & Hydraulic Valve
- Includes removable water filter

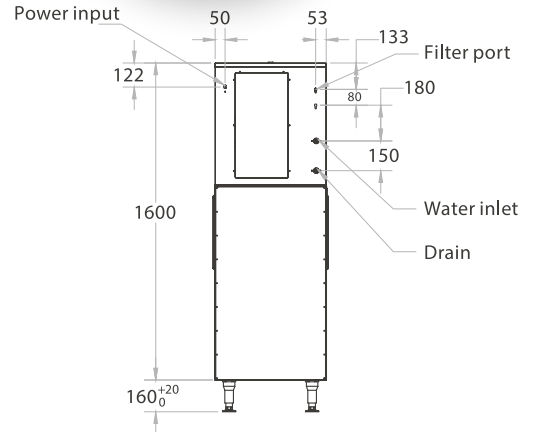
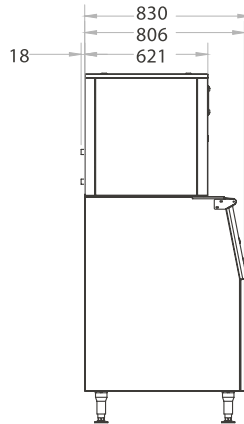
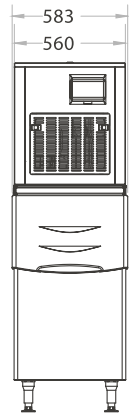

Code	Output (kg/24hrs)	Storage (kg)	Dimensions (WxDxH mm)	Weight (kg)	Voltage	Power (W/A)
SN-258N	250	125	560×830×1760	140	240	1160

ICE DISPENSER

- No touch, more convenient and hygienic for taking ice
- 304 grade stainless steel machine body
- Easy to operate and maintain
- Efficient ice dispensing
- Adjustable feet
- SD-130B Ice dispenser can also work with SN-420P, SN-145C, SN-280C machine head
- UV module with high sterilization efficiency

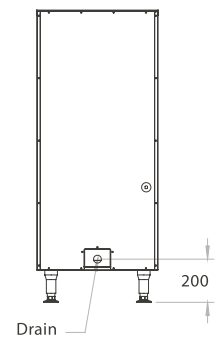
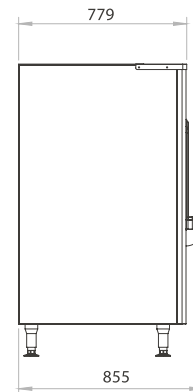
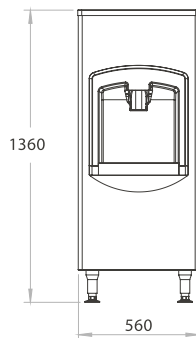

Code	Output (kg/24hrs)	Storage (kg)	Dimensions (WxDxH mm)	Weight (kg)	Voltage	Power (W/A)
SD-130B	7,200	60	560×855×1360	78	240	210

Allow 100mm clearance for installation, all vents must be left clear. Prices and specifications are subject to change without notice. Pictures are for illustrative purpose and final product may differ