

SUC/SUF TROPICALISED GLASS UPRIGHT FRIDGES & FREEZERS



HEAVY DUTY lockable units with factory balanced system which improves temperature recovery times, cools the cabinet quicker keeping food fresher for longer & lowering running costs.

- Embraco compressors & German EBM-Pabst fans
- Patterned design digital temp. controller & read-out
- 4 levels of shelving plus floor
- Fan-forced evaporator cooling
- Auto defrost
- Self evaporating drainage
- Insulation is CFC & HCFC free
- Extremely efficient self-closing doors with locks
- Internal corners are rounded for hygiene & easy cleaning
- Lighting inside
- Double glazed glass door for fridge
- Triple glazed heated glass door for freezer
- Castors
- Not suitable for storing food

NEW upgraded touch pad controller

SUCG500 / SUFG500

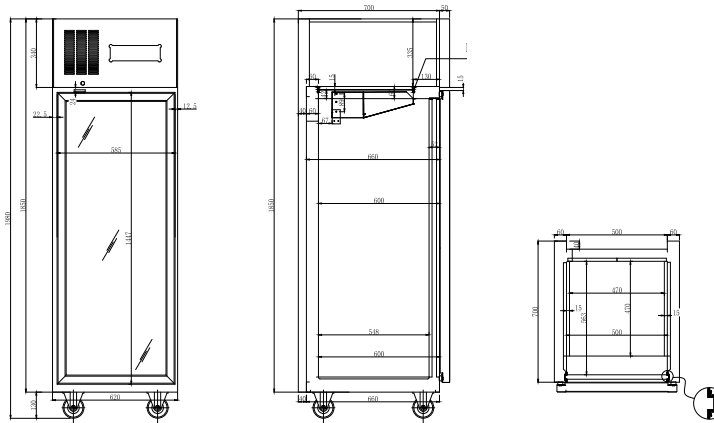

AMBIENT 38°C

SUCG1000 / SUFG1000

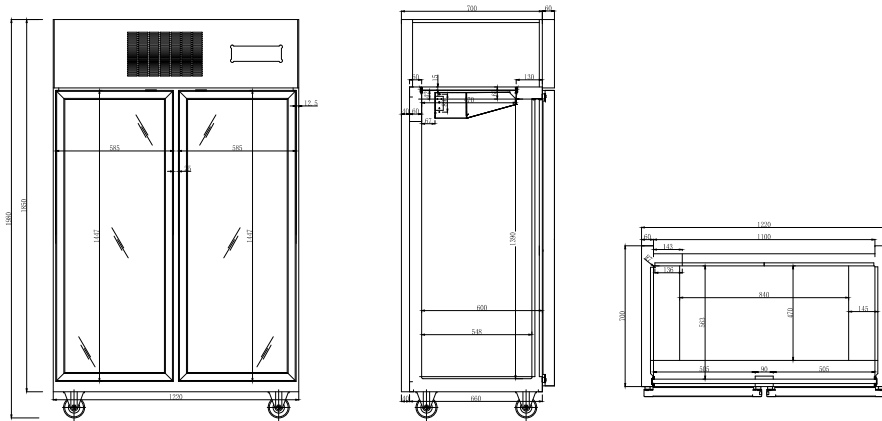

Code	Lite	Dimensions (WxDxH mm)	Weight (kg)	Temperature Range	Ambient/ RH%	Voltage	Power (W/A)
Single door fridges							
SUCG500	500	620x760x1980	110	+2 to +5	38/50	240	330/10
Single door freezer							
SUFG500	500	620x760x1980	118	-22 to -18	38/50	240	680/10
Double door fridges							
SUCG1000	1000	1220x760x1980	151	+2 to +5	38/50	240	580/10
Double door freezer							
SUFG1000	1000	1220x760x1980	172	-22 to -18	38/70	240	1100/10

Allow 100mm clearance for installation, all vents must be left clear. Prices and specifications are subject to change without notice. Pictures are for illustrative purpose and final product may differ