

TROPICALISED GLASS UPRIGHT FRIDGES

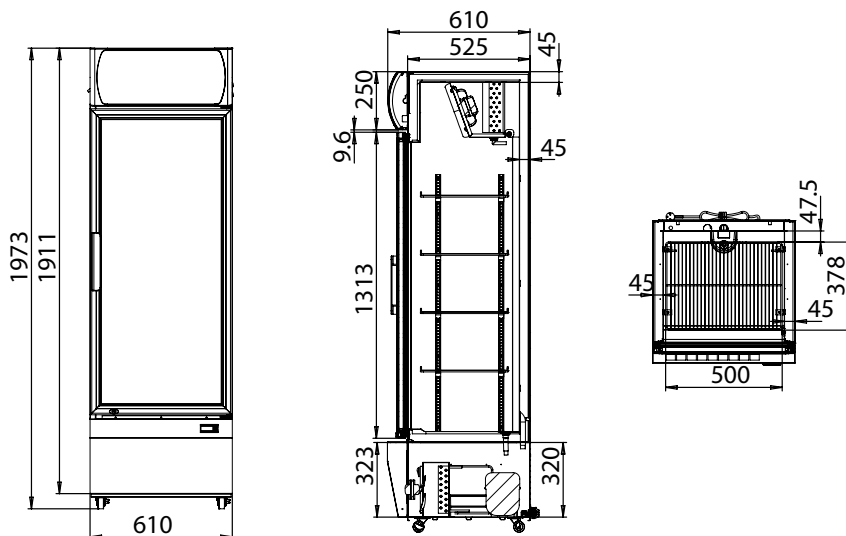

- Tropicalized refrigeration units with enhanced performance
- Double glazed glass door with heating elements
- Illuminated canopy
- LED lighting
- Easy adjustable shelves
- Self-closing glass door
- External door handle
- White powder coated steel plate
- Automatic defrost and condensate evaporation
- Lock & key
- Heavy duty castors with brake (4pcs, 2 with stopper)
- Digital Temperature controller
- 43°C operating temperature

LG-370PT



LG-1000PT

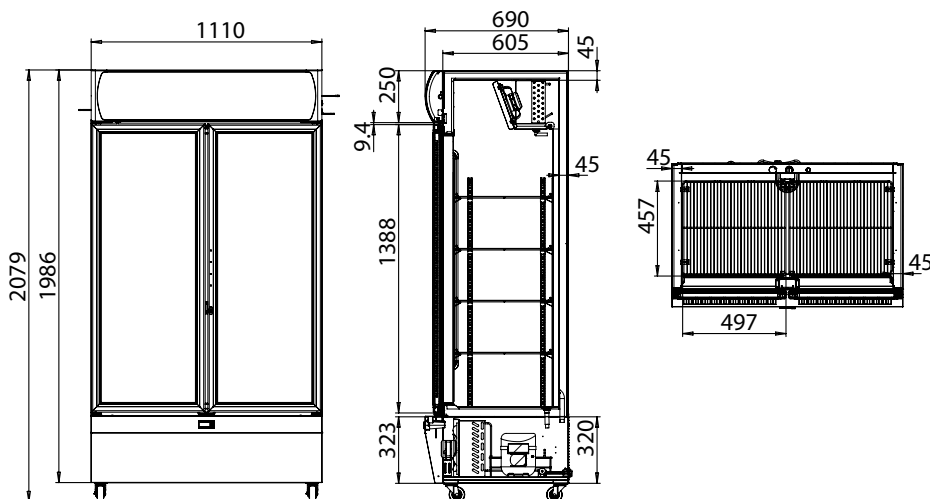

Code	Litre	Shelves	Dimensions (WxDxH mm)	Weight (kg)	Temperature Range	Ambient/ RH%	Voltage	Power (W/A)
Single door fridges								
LG-370PT	370	5	610x600x1973	80	+2 to +8	43/60	240	480/10
Double door fridges								
LG-1000PT	885	5	1110x680x2079	154	+2 to +8	43/60	240	694/10

Allow 100mm clearance for installation, all vents must be left clear. Prices and specifications are subject to change without notice. Pictures are for illustrative purpose and final product may differ