

COLD DISPLAY 3 SHELVES

- Double glazed and heated glass for clear vision
- Rear sliding removable doors for easy cleaning
- LED lighting on each shelf for excellent illumination
- Stainless steel mirror base
- 3 shelves plus bottom
- 32°C ambient at 60% RH
- Easily accessible cooling system for easy cleaning
- Digital temperature control
- Ventilated cooling system by controlling humidity at low temperature
- Auto defrost
- Operating temperature: 2°C~8°C
- Compressor: Secop
- Fitted with castors for easy mobility
- Warranty: 1 Year Parts and Labour + 1 Year Additional Parts

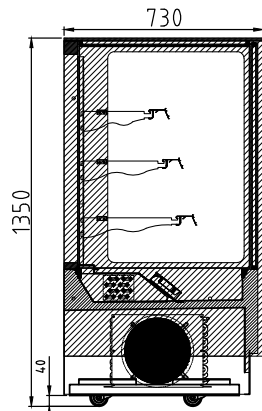

GAN-1200RF3

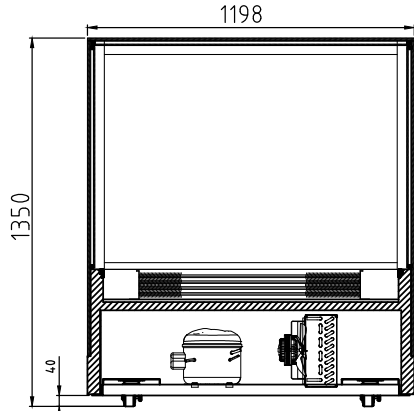

GAN-1500RF3

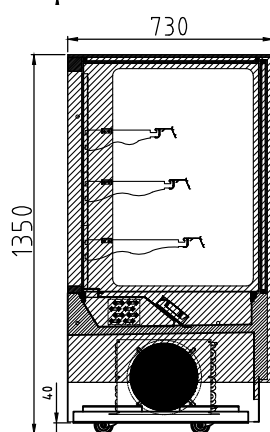
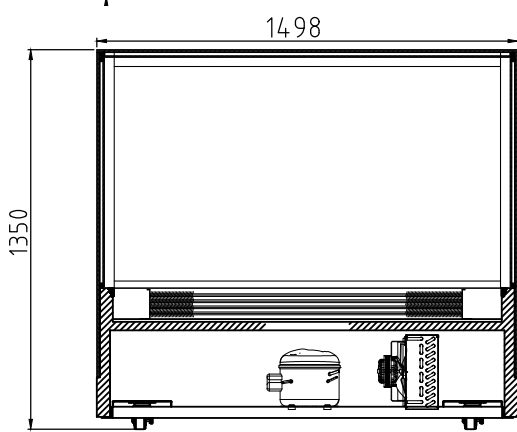

GAN-1800RF3

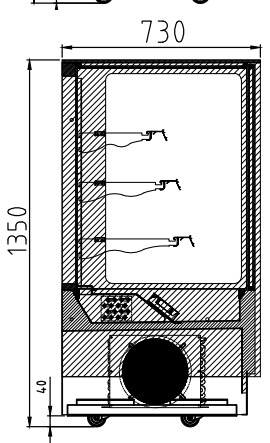
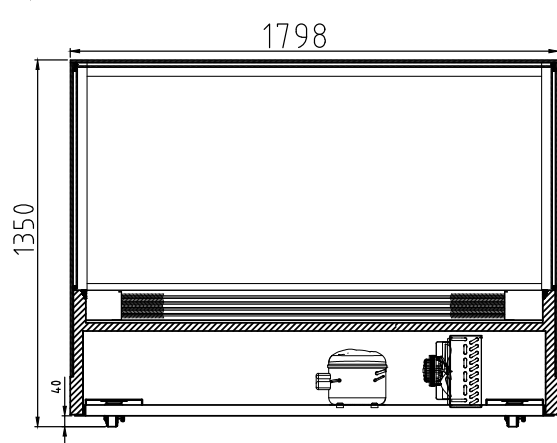

Code	GEMS Star Rating	Litre	Dimensions (WxDxH mm)	Weight (kg)	Temperature Range °C	Ambient/ RH%	Voltage	Power (W/A)
GAN-900RF3	8	460	900x730x1350	240	+2 to +8	32/60	240	550/10
GAN-1200RF3	8	615	1200x730x1350	280	+2 to +8	32/60	240	630/10
GAN-1500RF3	7	770	1500x730x1350	320	+2 to +8	32/60	240	750/10
GAN-1800RF3	6	925	1800x730x1350	360	+2 to +8	32/60	240	870/10

Allow 100mm clearance for installation, all vents must be left clear. Prices and specifications are subject to change without notice. Pictures are for illustrative purpose and final product may differ