

TWT-48F-HC

 Worktop Counter Freezer, 2 Solid Swing Doors

Dimensions		Build		Technical	
External Width (mm)	1229	Door Description	2 Solid Swing Doors	Temperature Holding	-23°C
External Depth (mm)	766	Exterior Construction	Stainless steel front & countertop, aluminium sides & rear	Refrigerant	R290
External Height (mm)	1004	Interior Construction	Clear coated aluminium, stainless steel base	Voltage / Frequency / Phase	220-240V/50Hz/1
Exclusions	Depth does not include 26 mm for rear bumpers.	Air Intake Position	Front	Amps	1.8
Net Volume (Litres)	278	Ventilation Position	Front	60Hz model Amps	2.7
Gross Volume (Litres)	340	Clearance Required	Zero back and sides	Wattage	414
Supplied Shelves	4	Cord Length (Meters)	2.13	60Hz model Wattage	621
Shelf Size (L x D mm)	Two 547 x 514 + Two 547 x 349	Standard w/ Locks	Standard	Climate Class	4
Internal Net Height (mm)	630			Operating Statement	Regular Duty: This appliance is intended for use in ambient temperatures up to 30°C.
Unpackaged Weight (kg)	119			Testing Standard	EN 16825
Packaged Weight (kg)	130			EEC	D
Packaged Dimensions (W x D x H mm)	1296 x 839 x 1207			EEl	50.8
Supplied Supports	ø 127 mm castors (158 mm height)			kWh/24hr	5.57
				kWh/Annum	2036
				Defrost Type	Auto



Specifications subject to change without notice.
 Technical data above related to energy use based on testing of 50Hz or Dual Frequency models
 Chart dimensions rounded up to the next whole millimeter (inches rounded up to the 1/8")

UK & Ireland [0800 783 2049](tel:08007832049)
 EMEA [+41 61 563 07 05](tel:+41615630705)
 Australia [+61 2 9619 9999](tel:+61296199999)

TfIUK@truemfg.com
TrueCHCustomerService@truemfg.com
TrueRefAus@truemfg.com



TWT-48F-HC

 Worktop Counter Freezer, 2 Solid Swing Doors

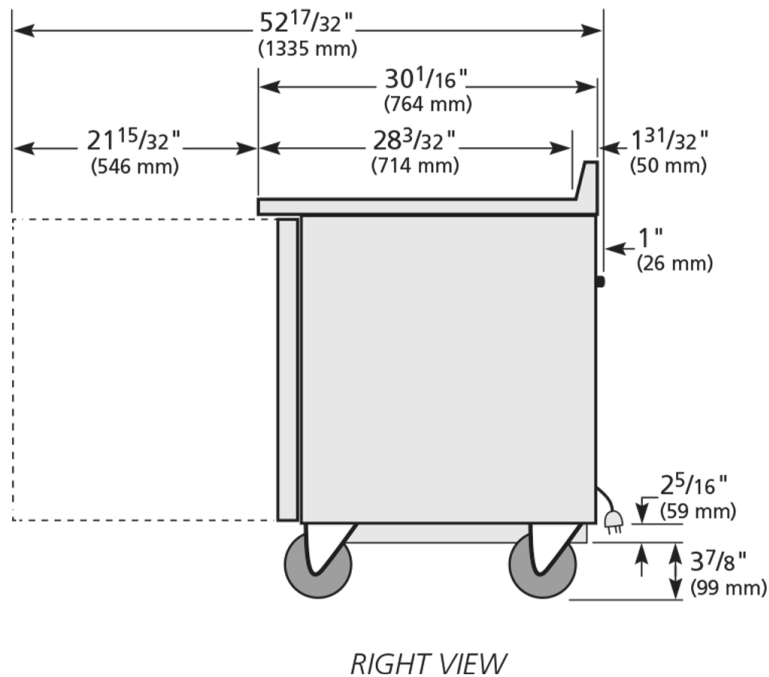
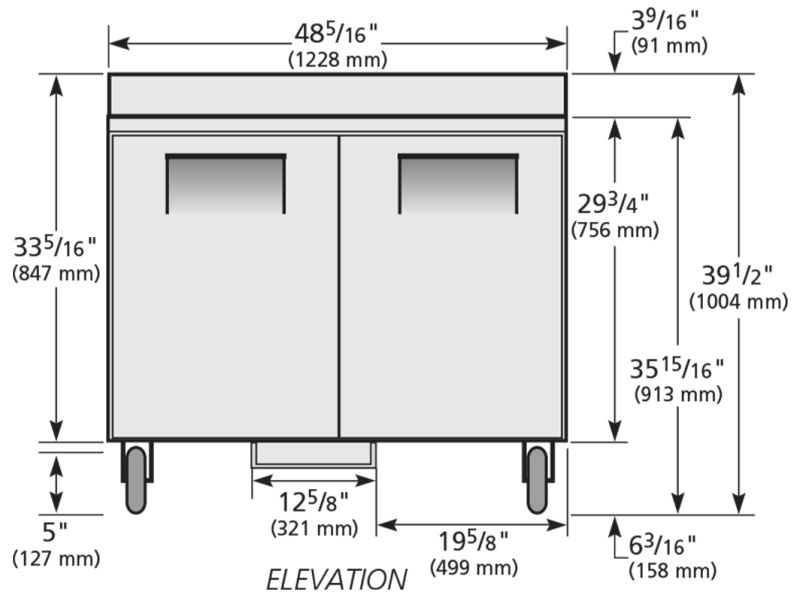

Specifications subject to change without notice.
 Technical data above related to energy use based on testing of 50Hz or Dual Frequency models
 Chart dimensions rounded up to the next whole millimeter (inches rounded up to the 1/8")

UK & Ireland [0800 783 2049](tel:08007832049)
 EMEA [+41 61 563 07 05](tel:+41615630705)
 Australia [+61 2 9619 9999](tel:+61296199999)

TFIUK@truemfg.com
TrueCHCustomerService@truemfg.com
TrueRefAus@truemfg.com

