

TUC-48G-HC~FGD01

 Undercounter Foodservice Refrigerator, 2 Glass Swing Doors

Dimensions		Build		Technical	
External Width (mm)	1229	Door Description	2 Full Glass Swing Doors	Temperature Holding	0.5 : 3.3°C
External Depth (mm)	766	Exterior Construction	Stainless steel front & countertop, aluminium sides & rear	Refrigerant	R290
External Height (mm)	839	Interior Construction	Clear coated aluminium, stainless steel base	Voltage / Frequency / Phase	220-240V/50-60Hz/1
Exclusions	Depth does not include 26mm for rear bumpers and 42mm for door handles.	Air Intake Position	Front	Amps	1
Net Volume (Litres)	278	Ventilation Position	Front	Wattage	230
Gross Volume (Litres)	340	Clearance Required	Zero back and sides	Temperature Class	M1
Display Area (m ²)	0.54	Cord Length (Meters)	2.13	Operating Statement	Heavy Duty: This appliance is intended for use in ambient temperatures up to 40°C.
Supplied Shelves	4	Internal Lighting	LED	Testing Standard	EN 23953
Shelf Size (L x D mm)	Two 547 x 514 + Two 547 x 349	Standard w/ Locks	Standard	EEC	B
Internal Net Height (mm)	630			EI	10.6
Unpackaged Weight (kg)	119			kWh/24hr	1.86
Packaged Weight (kg)	130			kWh/Annum	682
Packaged Dimensions (W x D x H mm)	1296 x 839 x 1207			Defrost Type	Auto
Supplied Supports	ø 64 mm castors (83 mm height) (reduced height option available, totals 810 mm)				

WARRANTY
PARTS, COMPRESSOR AND LABOUR
5 YEARS*

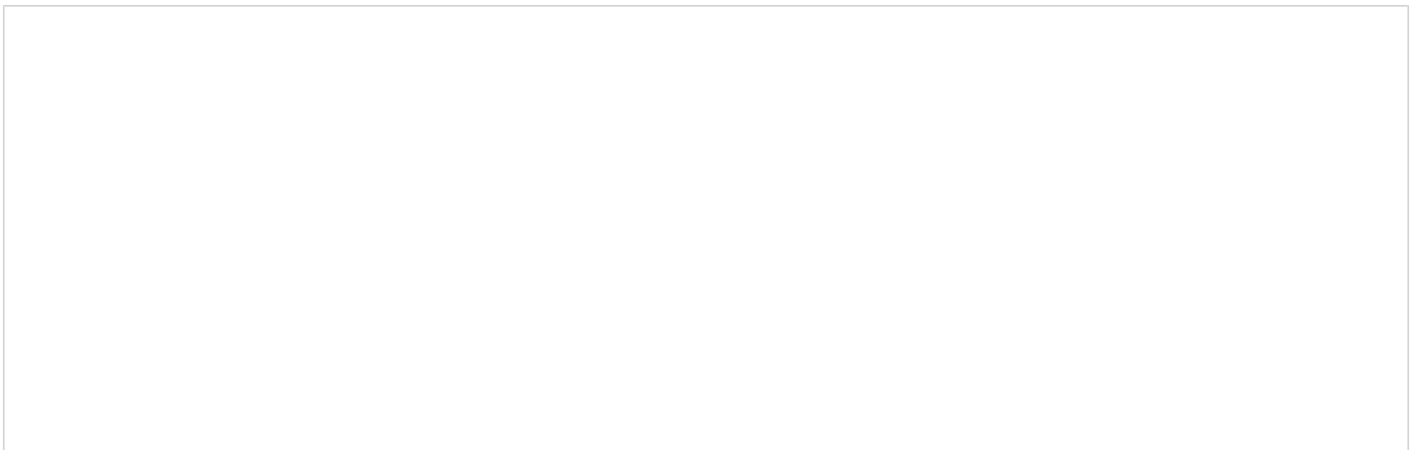

Specifications subject to change without notice.

 Technical data above related to energy use based on testing of 50Hz or Dual Frequency models
 Chart dimensions rounded up to the next whole millimeter (inches rounded up to the 1/8")

 UK & Ireland [0800 783 2049](tel:08007832049)
 EMEA [+41 61 563 07 05](tel:+41615630705)
 Australia [+61 2 9619 9999](tel:+61296199999)
TFIUK@truemfg.com
TrueCHCustomerService@truemfg.com
TrueRefAus@truemfg.com

TUC-48G-HC~FGD01

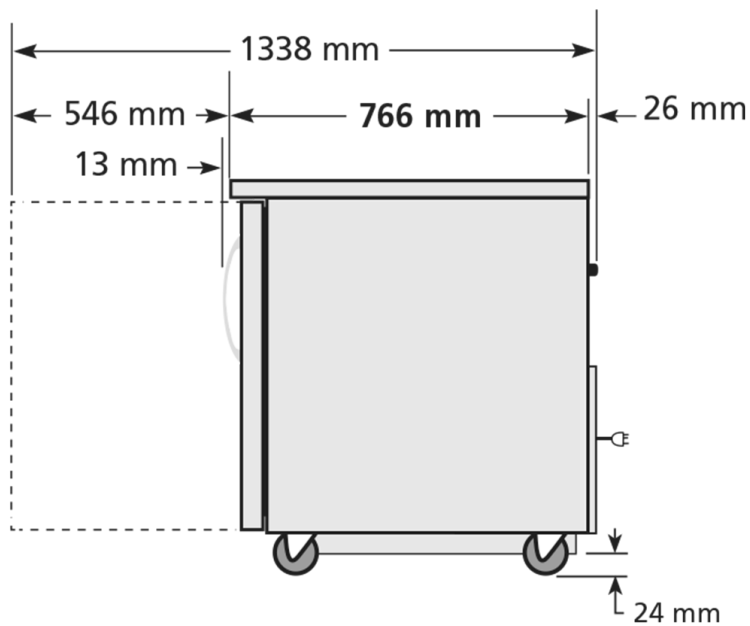
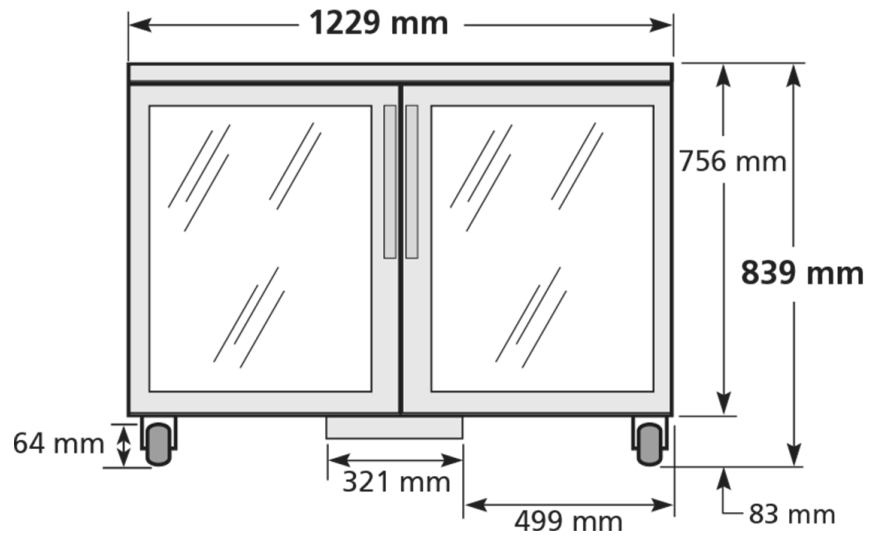
Undercounter Foodservice Refrigerator, 2 Glass Swing Doors



Specifications subject to change without notice.
Technical data above related to energy use based on testing of 50Hz or Dual Frequency models
Chart dimensions rounded up to the next whole millimeter (inches rounded up to the 1/8")

UK & Ireland [0800 783 2049](tel:08007832049)
EMEA [+41 61 563 07 05](tel:+41615630705)
Australia [+61 2 9619 9999](tel:+61296199999)

TFIUK@truemfg.com
TrueCHCustomerService@truemfg.com
TrueRefAus@truemfg.com

