



**TRUE REFRIGERATION
INTERNATIONAL**

UK Tel +44 (0) 1709 888 080 • Germany Tel +49 (0) 7622 6883 0
Free Phone to U.S. 0 800 894 928 • www.truemfg.com



9/19

**Model:
TUC-48D-4-LP-HC**

Undercounter:
Low Profile Drawered Refrigerator with Hydrocarbon Refrigerant



TUC-48D-4-LP-HC

- ▶ True's undercounter units are designed with enduring quality that protects your long term investment.
- ▶ Designed using the highest quality materials and components to provide the user with colder product temperatures, lower utility costs, exceptional food safety and the best value in today's food service marketplace.
- ▶ "Low Profile" models are designed to slide easily under custom built countertops.
- ▶ 1 1/2" (39mm) diameter dual swivel castors. 31 7/8" (810 mm) work surface height.
- ▶ Factory engineered, self-contained, capillary tube system using environmentally friendly R290 hydrocarbon refrigerant that has zero (0) ozone depletion potential (ODP), & three (3) global warming potential (GWP).
- ▶ Oversized, factory balanced, refrigeration system holds 33°F to 38°F (.5°C to 3.3°C).
- ▶ All stainless steel front, top and ends. Corrosion resistant GalFan coated steel back.
- ▶ Interior - attractive, NSF approved, clear coated aluminum liner with stainless steel floor.
- ▶ Each drawer accommodates one (1) full size 12"L x 18"W x 6"D (305 mm x 458 mm x 153 mm) food storage box (sold separately).
- ▶ Foamed-in-place using a high density, polyurethane insulation that has zero ozone depletion potential (ODP) and zero global warming potential (GWP).

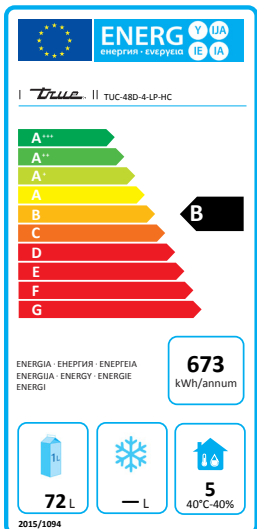

PLAN VIEW

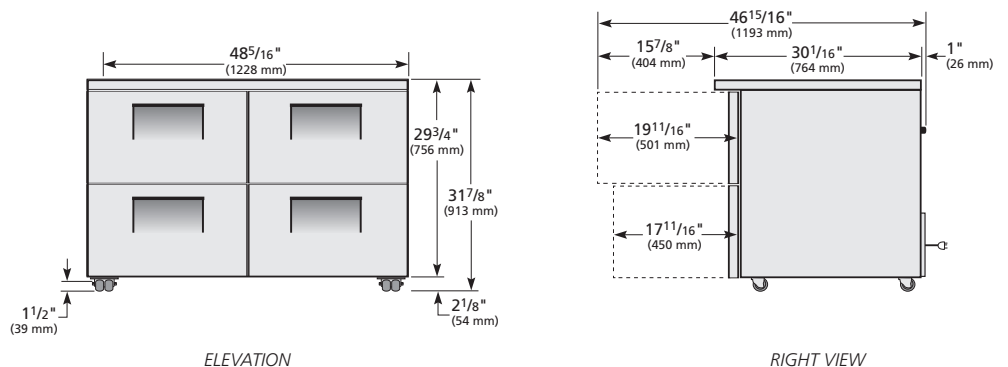

ROUGH-IN DATA

Specifications subject to change without notice.
Chart dimensions rounded up to the next whole millimeter (inches rounded up to the next 1/8").

Model	Model Type	Drawers	Cabinet Dimensions (mm)			Net Volume (litres)	EEC	EEI	24 hr/ Energy Consumption (kWh)	Annual Energy Consumption (kWh)	Crated Weight (kg)
			W	D	H						
TUC-48D-4-LP-HC	Counter Chilled	4	1229	766	810	72	B	34.1	1.845	673	150

† Depth does not include 1" for rear bumpers.