

TSSU-60-16D-2-HC

🇺🇸 Prep Table, 16x 1/6 Top Pans, 2 Drawers + 1 Solid Swing Door



| Dimensions | | Build | | Technical | |
|------------------------------------|------------------------------------------------------------------------|-----------------------|-------------------------------------------------------------|-----------------------------|--------------------|
| External Width (mm) | 1534 | Door Description | 1 Solid Swing Door | Temperature Holding | 0.5 : 5°C |
| External Depth (mm) | 766 | Number of Drawers | 2 | Refrigerant | R290 |
| External Height (mm) | 1093 | Drawers location | Left (standard) or Right (option) | Voltage / Frequency / Phase | 220-240V/50-60Hz/1 |
| Exclusions | Depth does not include 26 mm for rear bumpers. Height with lid closed. | Exterior Construction | Stainless steel front, top & hood, aluminium sides and rear | Amps | 2.2 |
| Gross Volume (Litres) | 439 | Interior Construction | Clear coated aluminium, stainless steel base | Wattage | 506.00000000000006 |
| Supplied Shelves | 2 | Air Intake Position | Front | Defrost Type | Auto |
| Shelf Size (L x D mm) | One 700 x 546 + One 700 x 349 | Ventilation Position | Front | | |
| Internal Net Height (mm) | 535 | Clearance Required | Zero back and sides | | |
| Top Pans Supplied (max depth mm) | 16x 1/6 GN (100) | Cord Length (Meters) | 3.35 | | |
| Per Drawer Capacity (max depth mm) | 1x 1/1 GN (150) | Standard w/ Locks | Not standard (SPEC3 option) | | |
| Unpackaged Weight (kg) | 173 | | | | |
| Packaged Weight (kg) | 184 | | | | |
| Packaged Dimensions (W x D x H mm) | 1601 x 832 x 1270 | | | | |
| Cutting Board (L x D mm) | 1534 x 299 | | | | |
| Supplied Supports | ∅ 127 mm castors (158 mm height) | | | | |



Specifications subject to change without notice.
Technical data above related to energy use based on testing of 50Hz or Dual Frequency models
Chart dimensions rounded up to the next whole millimeter (inches rounded up to the 1/8")

UK & Ireland [0800 783 2049](tel:08007832049)
EMEA [+41 61 563 07 05](tel:+41615630705)
Australia [+61 2 9619 9999](tel:+61296199999)

TFIUK@truemfg.com
TrueCHCustomerService@truemfg.com
TrueRefAus@truemfg.com



TSSU-60-16D-2-HC

Prep Table, 16x 1/6 Top Pans, 2 Drawers + 1 Solid Swing Door

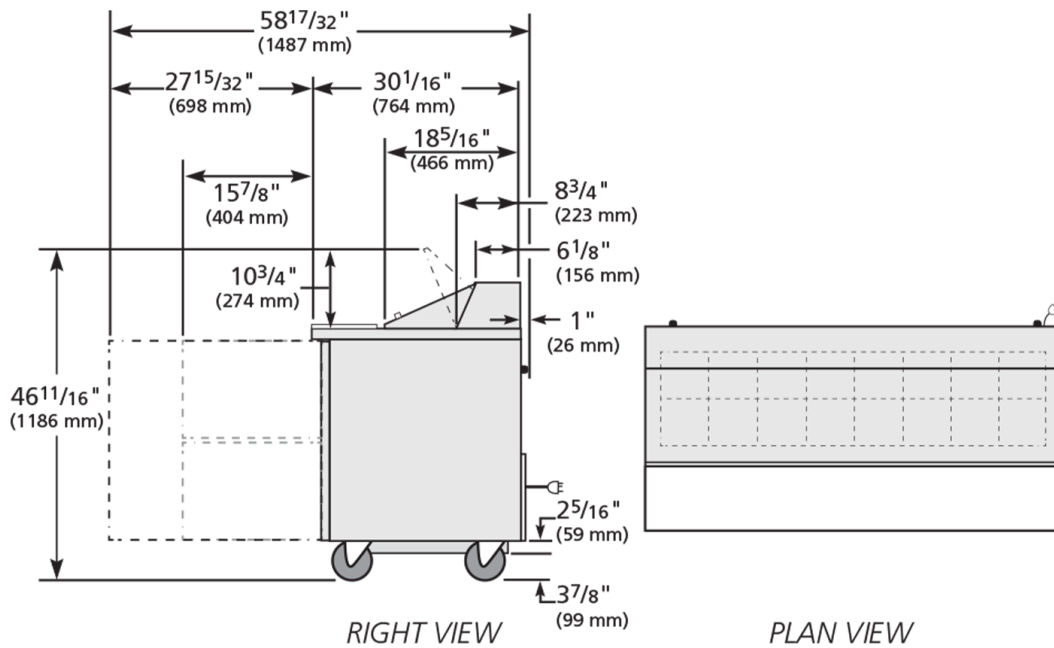
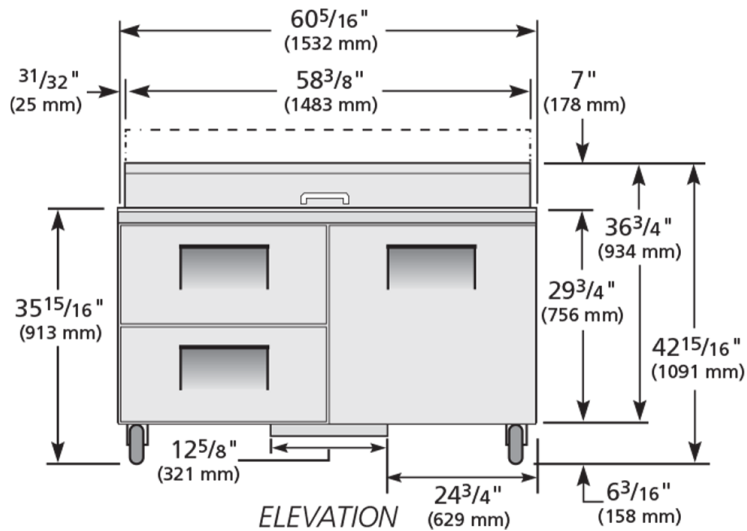

Specifications subject to change without notice.
 Technical data above related to energy use based on testing of 50Hz or Dual Frequency models
 Chart dimensions rounded up to the next whole millimeter (inches rounded up to the 1/8")

UK & Ireland [0800 783 2049](tel:08007832049)
 EMEA [+41 61 563 07 05](tel:+41615630705)
 Australia [+61 2 9619 9999](tel:+61296199999)

TFIUK@truemfg.com
TrueCHCustomerService@truemfg.com
TrueRefAus@truemfg.com

