

Under-equipment Stands

# TRCB-48-HC

 Under-Equipment Refrigerator, 2 Drawers



Dimensions		Build		Technical	
External Width (mm)	1227	Number of Drawers	2	Temperature Holding	0.5 : 3.3°C
External Depth (mm)	816	Exterior Construction	Stainless steel front and top, aluminium sides and rear	Refrigerant	R290
External Height (mm)	648	Interior Construction	Clear coated aluminium, stainless steel base	Voltage / Frequency / Phase	220-240V/50-60Hz/1
Exclusions	Depth does not include 26 mm for rear bumpers.	Air Intake Position	Front	Amps	1.1
Net Volume (Litres)	52	Ventilation Position	Right side	Wattage	253.00000000000003
Gross Volume (Litres)	252	Clearance Required	26 mm rear, 26 mm right side. Minimum clearance of 102 mm is required between bottom of cooking equipment heating element and the TRCB top.	Climate Class	5
Per Drawer Capacity (max depth mm)	2x 1/1 GN (100)	Cord Length (Meters)	2.13	Operating Statement	Heavy Duty: This appliance is intended for use in ambient temperatures up to 40°C.
Unpackaged Weight (kg)	118	Max Weight Supported (kg)	326	Testing Standard	EN 16825
Packaged Weight (kg)	129	Standard w/ Locks	Not standard (build option)	EEC	C
Packaged Dimensions (W x D x H mm)	1372 x 889 x 749			EEl	42.4
Supplied Supports	ø 102 mm castors (127 mm height)			kWh/24hr	2.235
				kWh/Annum	816
				Defrost Type	Auto



Specifications subject to change without notice.  
 Technical data above related to energy use based on testing of 50Hz or Dual Frequency models  
 Chart dimensions rounded up to the next whole millimeter (inches rounded up to the 1/8")

UK & Ireland [0800 783 2049](tel:08007832049)  
 EMEA [+41 61 563 07 05](tel:+41615630705)  
 Australia [+61 2 9619 9999](tel:+61296199999)

[TfIUK@truemfg.com](mailto:TfIUK@truemfg.com)  
[TrueCHCustomerService@truemfg.com](mailto:TrueCHCustomerService@truemfg.com)  
[TrueRefAus@truemfg.com](mailto:TrueRefAus@truemfg.com)



# TRCB-48-HC

 Under-Equipment Refrigerator, 2 Drawers

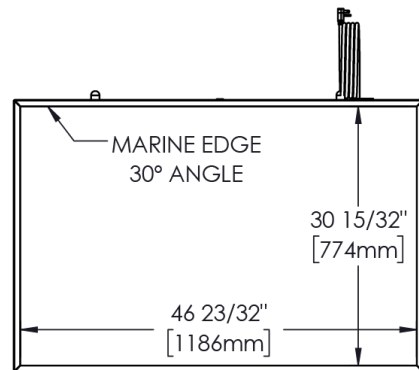
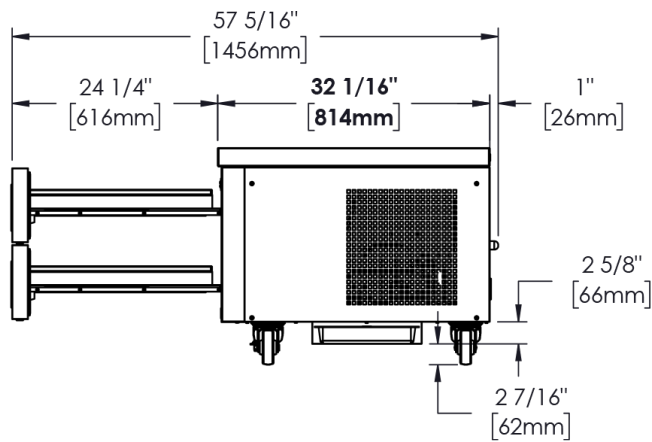
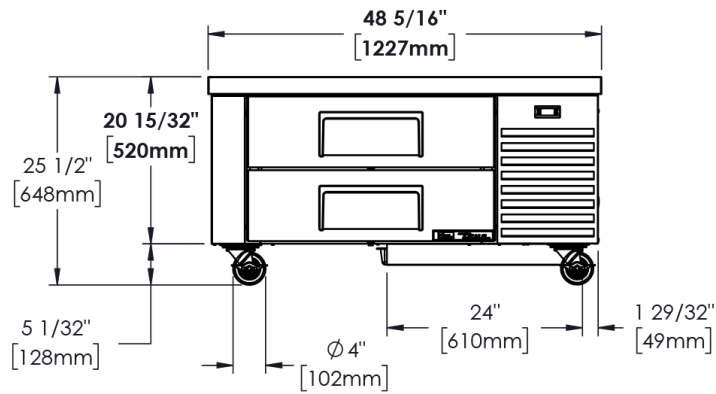

Specifications subject to change without notice.  
 Technical data above related to energy use based on testing of 50Hz or Dual Frequency models  
 Chart dimensions rounded up to the next whole millimeter (inches rounded up to the 1/8")

UK & Ireland [0800 783 2049](tel:08007832049)  
 EMEA [+41 61 563 07 05](tel:+41615630705)  
 Australia [+61 2 9619 9999](tel:+61296199999)

[TFIUK@truemfg.com](mailto:TFIUK@truemfg.com)  
[TrueCHCustomerService@truemfg.com](mailto:TrueCHCustomerService@truemfg.com)  
[TrueRefAus@truemfg.com](mailto:TrueRefAus@truemfg.com)

