

Prep Tables

# TFP-64-24M-FGLID-HC

 Glass Lid Prep Table, 24x 1/6 Top Pans, 2 Solid Swing Doors



Dimensions		Build		Technical	
External Width (mm)	1629	Door Description	2 Solid Swing Doors	Temperature Holding	0.5 : 5°C
External Depth (mm)	801	Exterior Construction	Stainless steel front, aluminium sides and rear	Refrigerant	R290
External Height (mm)	966	Interior Construction	Clear coated aluminium, stainless steel base	Voltage / Frequency / Phase	220-240V/50Hz/1
Exclusions	Depth does not include 51 mm for cutting board overhang. Height with lid closed.	Air Intake Position	Front	Amps	1.9
Gross Volume (Litres)	623	Ventilation Position	Front	Wattage	437
Supplied Shelves	4	Clearance Required	Zero back and sides	Defrost Type	Auto
Shelf Size (L x D mm)	750 x 508	Cord Length (Meters)	2.13		
Internal Net Height (mm)	500	Standard w/ Locks	Not standard (SPEC3 option)		
Top Pans Supplied (max depth mm)	24x 1/6 GN (100)				
Unpackaged Weight (kg)	249				
Packaged Weight (kg)	260				
Packaged Dimensions (W x D x H mm)	1723 x 864 x 1385				
Cutting Board (L x D mm)	1629 x 204				
Supplied Supports	Built-in recessed castors (19 mm clearance)				



Specifications subject to change without notice.  
 Technical data above related to energy use based on testing of 50Hz or Dual Frequency models  
 Chart dimensions rounded up to the next whole millimeter (inches rounded up to the 1/8")

UK & Ireland [0800 783 2049](tel:08007832049)  
 EMEA [+41 61 563 07 05](tel:+41615630705)  
 Australia [+61 2 9619 9999](tel:+61296199999)

[TFIUK@truemfg.com](mailto:TFIUK@truemfg.com)  
[TrueCHCustomerService@truemfg.com](mailto:TrueCHCustomerService@truemfg.com)  
[TrueRefAus@truemfg.com](mailto:TrueRefAus@truemfg.com)



# TFP-64-24M-FGLID-HC

🇬🇧 Glass Lid Prep Table, 24x 1/6 Top Pans, 2 Solid Swing Doors

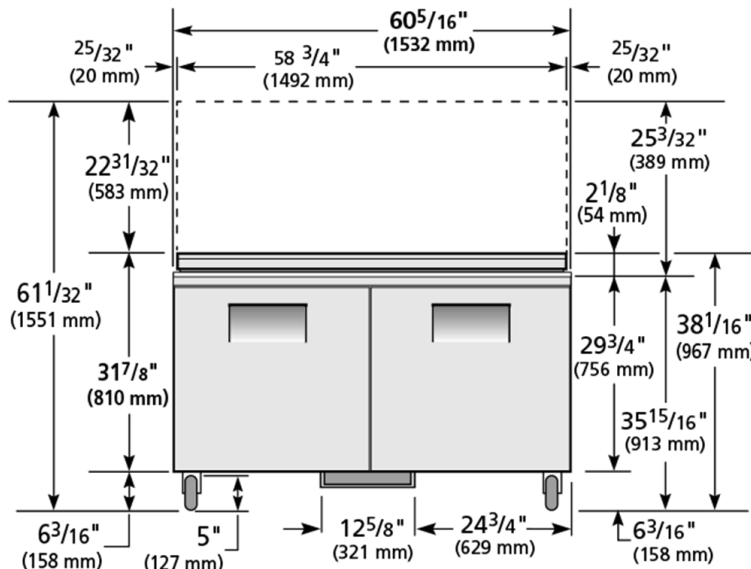

ELEVATION

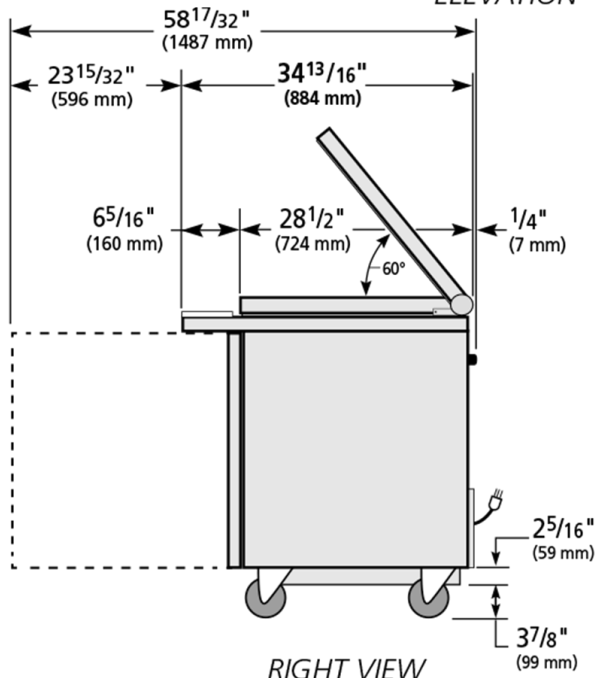

RIGHT VIEW

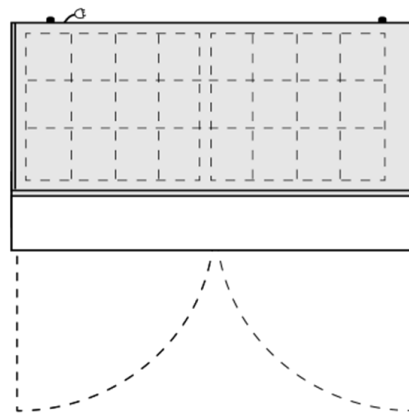

PAN LAYOUT



Specifications subject to change without notice. Technical data above related to energy use based on testing of 50Hz or Dual Frequency models Chart dimensions rounded up to the next whole millimeter (inches rounded up to the 1/8")

UK & Ireland 0800 783 2049  
 EMEA +41 61 563 07 05  
 Australia +61 2 9619 9999

TFIUK@truemfg.com  
 TrueCHCustomerService@truemfg.com  
 TrueRefAus@truemfg.com

