

TBR52-RISZ1-L-S-SS-2

 Bar Refrigerator, Stainless Steel Ext, 2 Solid Swing Doors



Dimensions		Build		Technical	
External Width (mm)	1321	Door Description	2 Solid Swing Doors	Temperature Holding	0.5 : 3.3°C
External Depth (mm)	631	Exterior Construction	Stainless Steel front and countertop. Matching Aluminium sides & rear.	Refrigerant	R290
External Height (mm)	881	Interior Construction	Stainless Steel	Voltage / Frequency / Phase	220-240V/50-60Hz/1
Exclusions	Depth does not include 35 mm for door handle. Height does not include 7 mm for leg levelers.	Air Intake Position	Front	Amps	1.3
Gross Volume (Litres)	480	Ventilation Position	Front	Wattage	299
Supplied Shelves	6	Clearance Required	Zero back and sides	Defrost Type	Auto
Shelf Size (L x D mm)	450 x 458	Cord Length (Meters)	3.04		
Internal Net Height (mm)	730	Internal Lighting	LED		
Unpackaged Weight (kg)	150	Standard w/ Locks	standard		
Packaged Weight (kg)	161				
Packaged Dimensions (W x D x H mm)	1486 x 724 x 1067				
Supplied Supports	Leg Levellers (Castors supplied separate)				



Specifications subject to change without notice.
 Technical data above related to energy use based on testing of 50Hz or Dual Frequency models
 Chart dimensions rounded up to the next whole millimeter (inches rounded up to the 1/8")

UK & Ireland [0800 783 2049](tel:08007832049)
 EMEA [+41 61 563 07 05](tel:+41615630705)
 Australia [+61 2 9619 9999](tel:+61296199999)

TfIUK@truemfg.com
TrueCHCustomerService@truemfg.com
TrueRefAus@truemfg.com



TBR52-RISZ1-L-S-SS-2

Bar Refrigerator, Stainless Steel Ext, 2 Solid Swing Doors

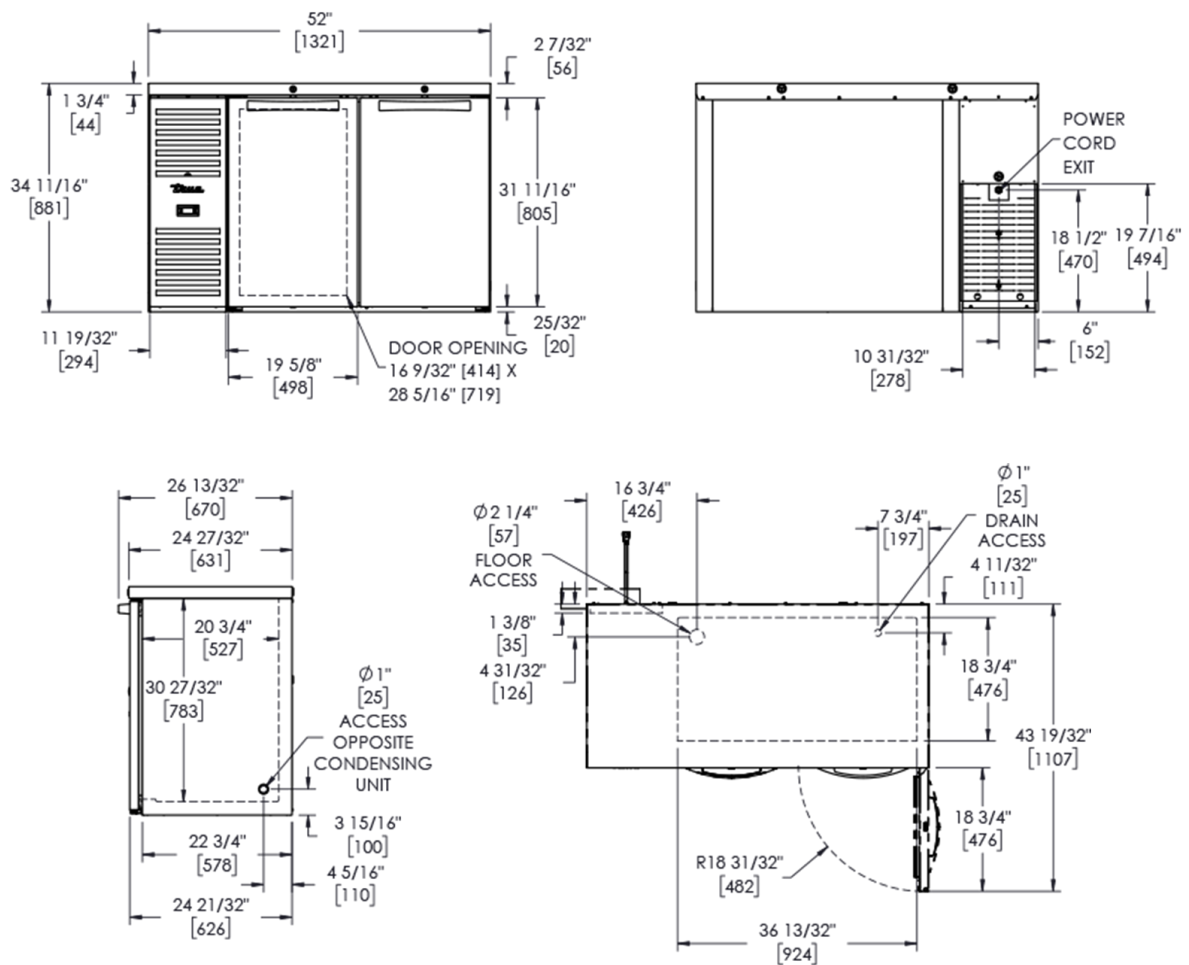

Specifications subject to change without notice. Technical data above related to energy use based on testing of 50Hz or Dual Frequency models Chart dimensions rounded up to the next whole millimeter (inches rounded up to the 1/8")

UK & Ireland 0800 783 2049
 EMEA +41 61 563 07 05
 Australia +61 2 9619 9999

TFIUK@truemfg.com
 TrueCHCustomerService@truemfg.com
 TrueRefAus@truemfg.com

