

TBR36-PTSZ1-L-S-G-G-2

 "Pass-Thru" Bar Refrigerator, Stainless Steel Ext, 1 Glass Swing Door Front, 1 Glass Swing Door Rear



Dimensions		Build		Technical	
External Width (mm)	914	Door Description	1 Full Glass Swing Door	Temperature Holding	0.5 : 3.3°C
External Depth (mm)	631	Door Opening	Left (standard) or Right. Field Reversible.	Refrigerant	R290
External Height (mm)	881	Exterior Construction	Stainless Steel front and countertop. Matching Aluminium sides & rear.	Voltage / Frequency / Phase	220-240V/50-60Hz/1
Exclusions	Depth does not include 35 mm for front + 35 mm for back door handles. Height does not include 7 mm for leg levelers.	Interior Construction	Stainless Steel	Amps	1.8
Gross Volume (Litres)	350	Air Intake Position	Front	Wattage	414
Supplied Shelves	3	Ventilation Position	Front	Defrost Type	Auto
Shelf Size (L x D mm)	394 x 458	Clearance Required	Zero back and sides		
Internal Net Height (mm)	730	Cord Length (Meters)	3.04		
Unpackaged Weight (kg)	121	Internal Lighting	LED		
Packaged Weight (kg)	132	Standard w/ Locks	standard		
Packaged Dimensions (W x D x H mm)	1083 x 801 x 1067				
Supplied Supports	Leg Levelers (Castors supplied separate)				



Specifications subject to change without notice.
 Technical data above related to energy use based on testing of 50Hz or Dual Frequency models
 Chart dimensions rounded up to the next whole millimeter (inches rounded up to the 1/8")

UK & Ireland [0800 783 2049](tel:08007832049)
 EMEA [+41 61 563 07 05](tel:+41615630705)
 Australia [+61 2 9619 9999](tel:+61296199999)

TFIUK@truemfg.com
TrueCHCustomerService@truemfg.com
TrueRefAus@truemfg.com



TBR36-PTSZ1-L-S-G-G-2

🇬🇧 "Pass-Thru" Bar Refrigerator, Stainless Steel Ext, 1 Glass Swing Door Front, 1 Glass Swing Door Rear

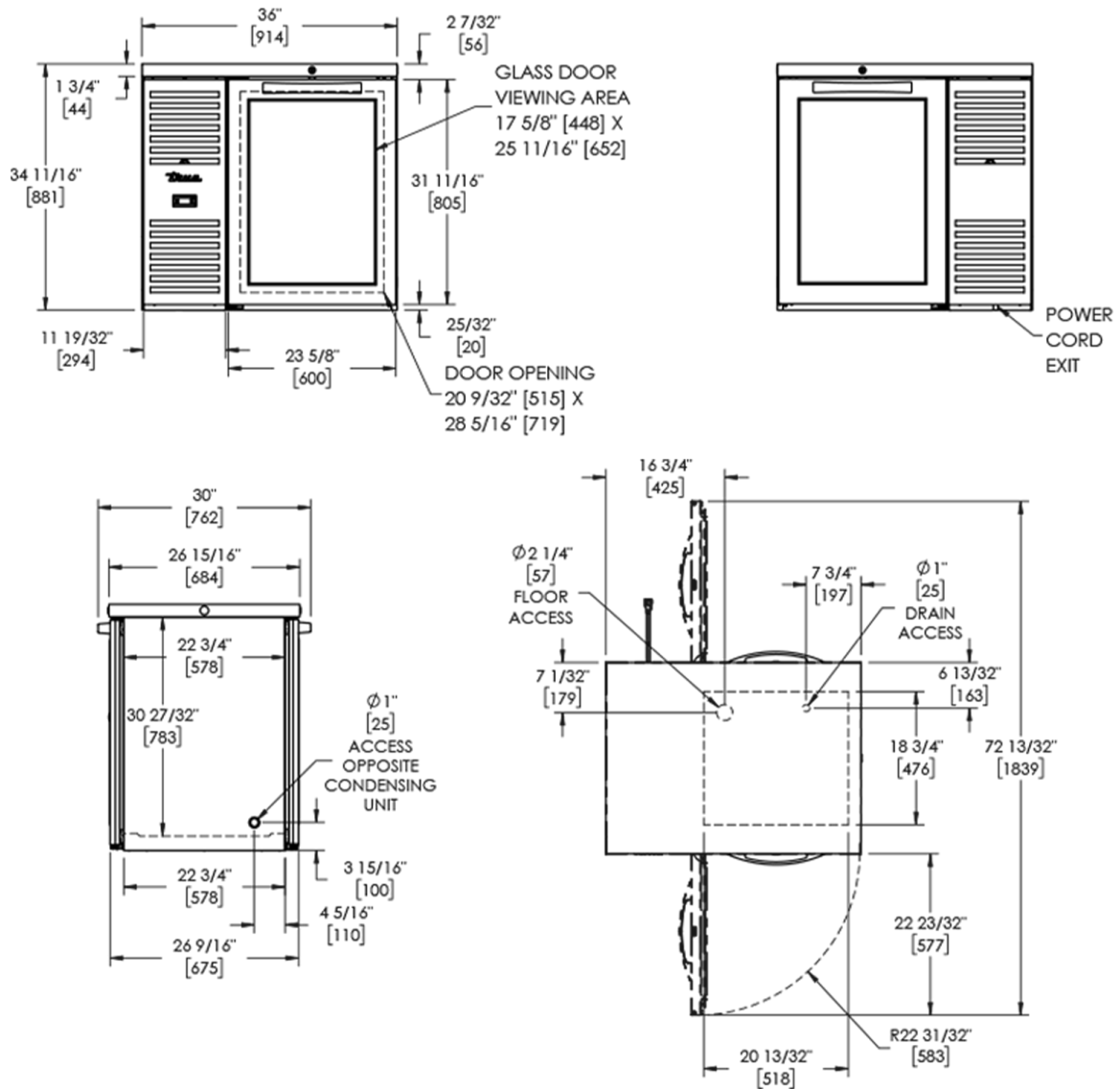

Specifications subject to change without notice. Technical data above related to energy use based on testing of 50Hz or Dual Frequency models Chart dimensions rounded up to the next whole millimeter (inches rounded up to the 1/8")

UK & Ireland [0800 783 2049](tel:08007832049)
 EMEA [+41 61 563 07 05](tel:+41615630705)
 Australia [+61 2 9619 9999](tel:+61296199999)

TFIUK@truemfg.com
TrueCHCustomerService@truemfg.com
TrueRefAus@truemfg.com

