

Upright Cabinets

T-19F-HC

 Upright Foodservice Freezer, 1 Full Solid Swing Door



Dimensions		Build		Technical	
External Width (mm)	686	Door Description	1 Solid Swing Door	Temperature Holding	-23°C
External Depth (mm)	623	Door Opening	Right (standard) or Left.	Refrigerant	R290
External Height (mm)	1995	Exterior Construction	Stainless steel front, aluminium sides & rear	Voltage / Frequency / Phase	220-240V/50Hz/1
Exclusions	Depth does not include 13 mm for rear access panel.	Interior Construction	Clear coated aluminium, stainless steel base	Amps	2.3
Net Volume (Litres)	350	Air Intake Position	Front	Wattage	529
Gross Volume (Litres)	538	Ventilation Position	Rear	Climate Class	5
Supplied Shelves	4	Clearance Required	26 mm rear, zero sides	Operating Statement	Heavy Duty: This appliance is intended for use in ambient temperatures up to 40°C.
Shelf Size (L x D mm)	582 x 464	Cord Length (Meters)	2.74	Testing Standard	EN 16825
Internal Net Height (mm)	1300	Internal Lighting	LED	EEC	D
Unpackaged Weight (kg)	109	Standard w/ Locks	standard	EEl	61.6
Packaged Weight (kg)	120			kWh/24hr	5.39
Packaged Dimensions (W x D x H mm)	788 x 788 x 2058			kWh/Annum	1970
Supplied Supports	ø 64 mm castors (83 mm height)			Defrost Type	Auto



Specifications subject to change without notice.
 Technical data above related to energy use based on testing of 50Hz or Dual Frequency models
 Chart dimensions rounded up to the next whole millimeter (inches rounded up to the 1/8")

UK & Ireland [0800 783 2049](tel:08007832049)
 EMEA [+41 61 563 07 05](tel:+41615630705)
 Australia [+61 2 9619 9999](tel:+61296199999)

TFIUK@truemfg.com
TrueCHCustomerService@truemfg.com
TrueRefAus@truemfg.com



T-19F-HC

Upright Foodservice Freezer, 1 Full Solid Swing Door

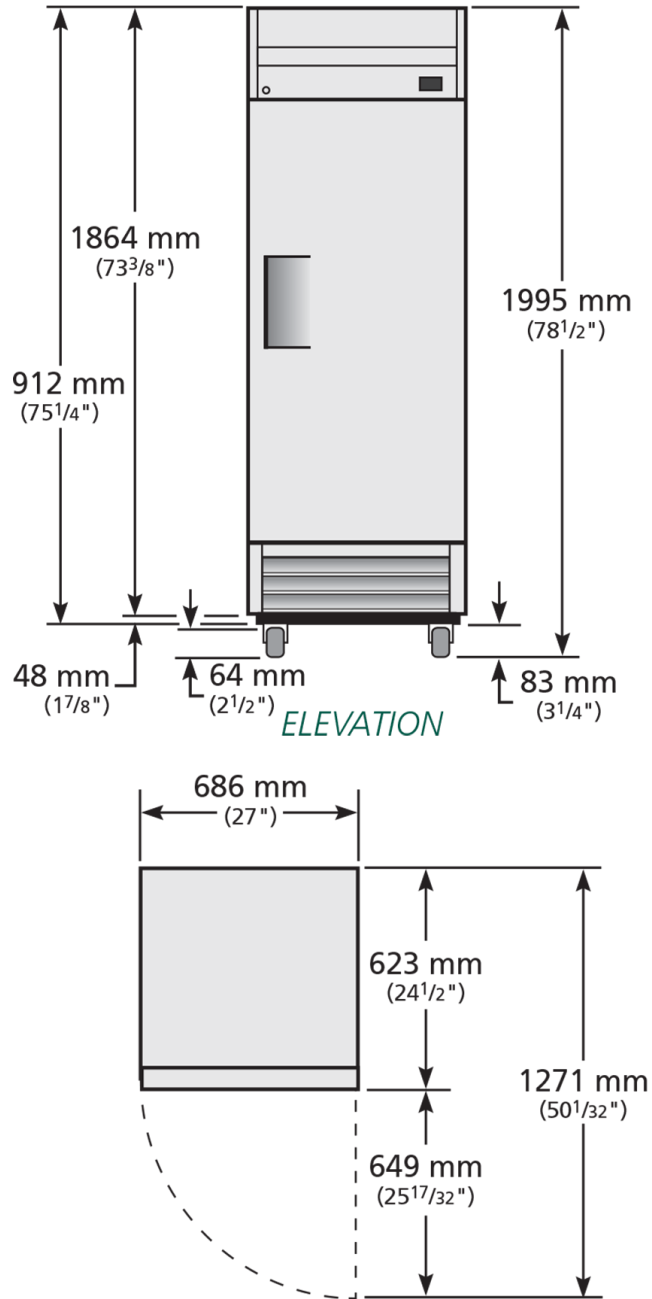

Specifications subject to change without notice.
Technical data above related to energy use based on testing of 50Hz or Dual Frequency models
Chart dimensions rounded up to the next whole millimeter (inches rounded up to the 1/8")

UK & Ireland 0800 783 2049
EMEA +41 61 563 07 05
Australia +61 2 9619 9999

TFIUK@truemfg.com
TrueCHCustomerService@truemfg.com
TrueRefAus@truemfg.com

