



WWW.DYNAMICMIXERS.COM

SMX SERIES



SMX 600 E



Ref. MX002



CE



15 / 50 gal.

TECHNICAL DATA

OUTPUT MAX	850 W
SPEED	9,500 R.P.M.
VOLTAGE	115 V or 230 V
TOTAL LENGTH	800 mm / 31.5"
MIXER TOOL LENGTH	530 mm / 20.8"
DIAMETER	125 mm / 4.9"
ACTUAL WEIGHT - SHIPPING WEIGHT	6.1 kg / 13.4 lbs - 7.7 kg / 17 lbs
MIXER TOOL	NON DETACHABLE

MAINTENANCE

Put the tube with the blade protector in clear water and start the machine for 3 seconds or more to clean the inside of the blade protector.

Clean the outside of the tube and the blade protector by passing it under the faucet.

Wash the motor block with a sponge or with a slightly damp cloth.

Never clean this machine with water jet spray.

ADVANTAGES

- Special huge volumes
- The new cooling technology ensures longer life to the mixer
- Non detachable mixer tool: ensures durability of the mixer
- All stainless steel mixer tool and handle support
- Ergonomic body
- Double insulation
- Titanium-plated blade easy to remove
- Easy manipulation into the pot thanks to its specific support bracket
- The continuous function auto run button allows to mix continuously or pulse.

USE

The SMX 600 E has been designed to work in containers holding up to 200 liters (50 gallons). It allows you to blend purees, mix and emulsify directly in the cooking pot. Indispensable for the preparation of soups, salad dressings, gravy, sauces, mayonnaise, refried beans, batters, and many other products.

Capacity: 75 to 200 L - 15 to 50 gal.



TECHNICAL SHEET

SMX 600 E MIXER

Parts list	Code
Aluminium Fan	0509
Carbon brushes (pair)	0529
Ball bearing	0601
Motor ball bearing	0602
Self-lubricating ring	0603
Waterproof seal	0607
O. ring	0610
Rubber washer	0760
Clips	0776
Washer & bolt for fan	0777
Wall bracket	0862
Strain relief 230 V	0950
Strain relief 115 V	0950.1
ID label 230 V	1007
ID label 115 V	1009
Bearing holder + seal	1185
Shaft & ball bearing	45120
Coupling sleeves	45122
Motor & shaft drive sprocket	45123
Fan housing Alu	45125
Fan housing Plastic	45125.P
Double isolation part	45126
Lower ball bearing assembly	45130
Complete stainless steel lower bearing	45130.1
Lower motor casing	45132
Upper motor casing	45133
Stator 230 V	45135
Stator 115 V	45135.1
Rotor 230 V	45136
Rotor 115 V	45136.1
Stator screws (2)	45137

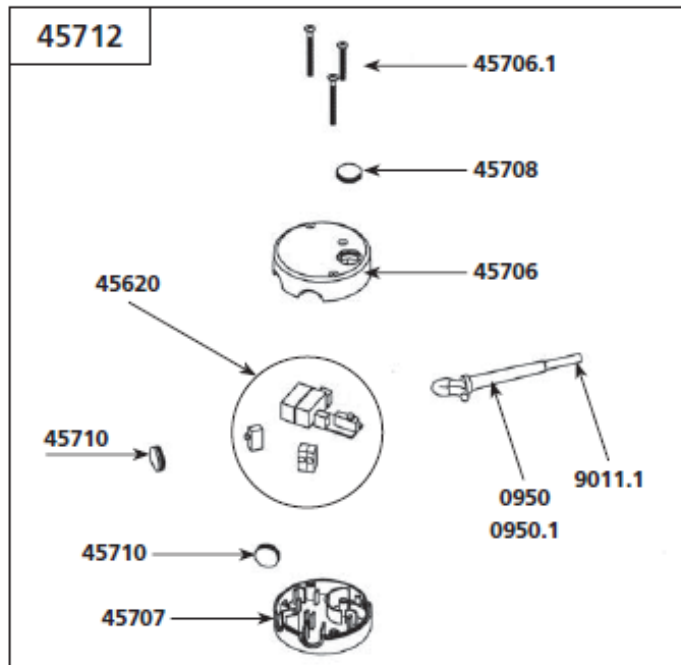
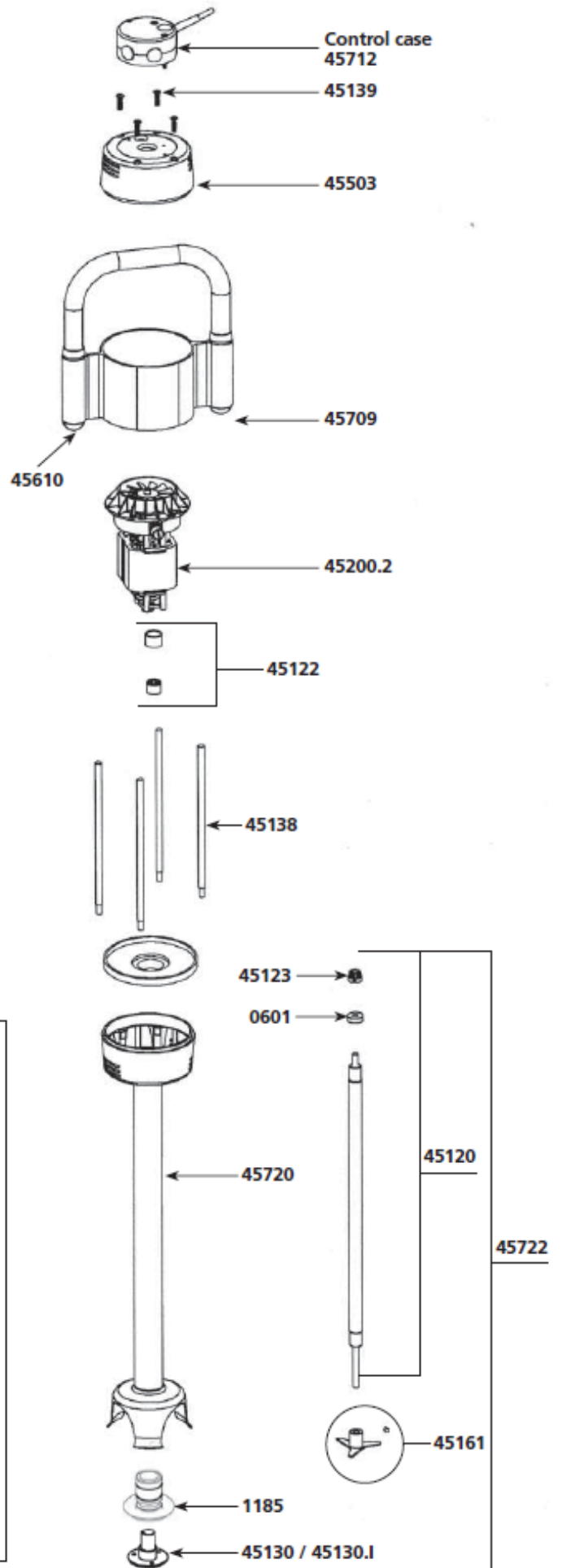

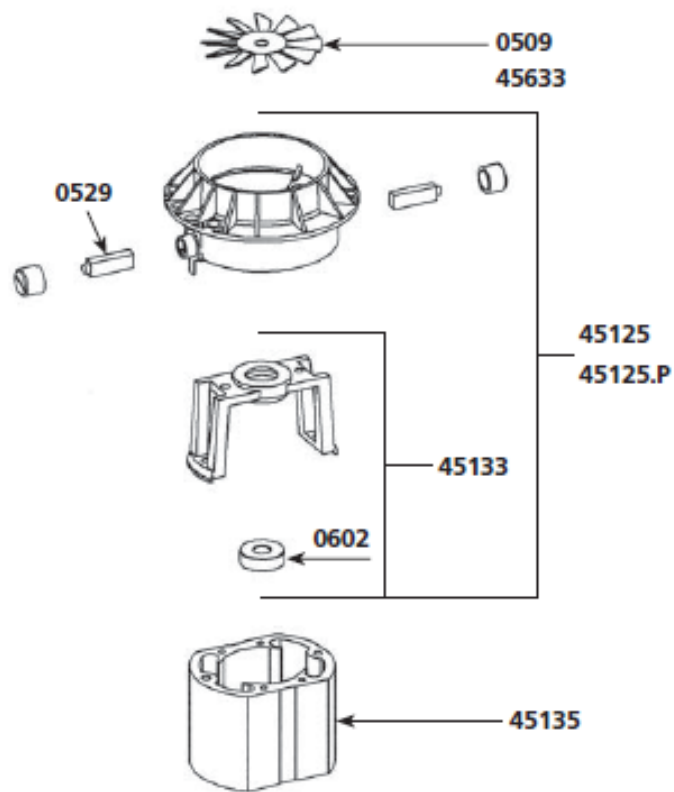

Parts list

Code

Braces (4)	45138
Brace screws (4)	45139
Cutter blade w/ screw	45161
Motor 115 V	45200.1
Motor 230 V	45200.2
Squeezing washers (4)	45230
Top housing	45503
Kit w/ shaft, lower bearing, coupler, cutter	45533
Handle cap (2)	45610
Circuit board	45620
Circuit board	45620.1
Plastic Fan	45633
Top housing (orange plastic piece)	45706
Screws control case set	45706.1
Lower housing (orange plastic piece)	45707
Handle cap protector (unit)	45708
Sleeve & complete handle & label & cap	45709
Handle cap protectors (unit)	45710
Lower housing w/ screws	45711
Complete control casing 230V	45712
Complete control casing 115V	45712.1
Foot assembly w/ lower bearing	45720
Complete foot assembly	45722
Power cord 230 V	9011.1
Power cord 115 V	9040.1
Power cord (Australian)	9066.1
Power cord (UK)	9067.1
Bearing support screws (3)	9902
Stainless steel lower bearing screws (3)	9902.1

