



RHENINGHAUS S.r.l.

Strada del Cascinotto, 139/39L – 10156 TORINO - ITALY

Tel. ++39 011 2237514-2201402

Fax ++39 011 2735109

e-mail: info@rheninghaus.com internet: www.rheninghaus.com

Distribution and service by



Instructions manual

SSR0220

SSR0250

SSR0300



WIRING DIAGRAM

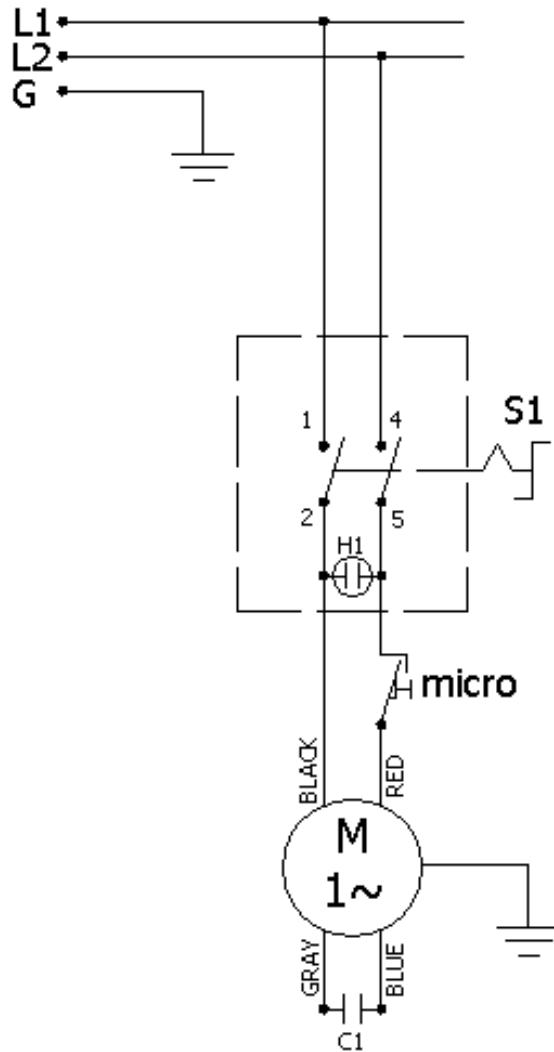

1 INTRODUCTION

We thank you to have chosen us. The machine you have chosen is built by using quality materials and up-to-date technologies. Your safety as well as that one of your customers and users is very important: the following instructions allow a safe machine use.

2 SAFETY

2.1 USE MANUAL

All operators involved in the present machine use, in installation, in maintenance and servicing, must be skilled enough and they must read this use manual carefully.

It is important that not qualified persons or children do not use, even by chance, this machine.

2.2 USED SYMBOLOGY IN USE MANUAL



CAUTION:

It means that if instruction is not followed, somebody could be injured.



ADVICES:

Useful information in order to obtain a better and safer machine use.

2.3 MAIN DANGER SOURCES

- Cutting danger: the machine has a sharp blade driven by a motor.
- Electric danger: the machine is fed by electric voltage.

2.4 NOISE

Machine noise is, in every phase of its use, lower than 70 dB.

2.5 PLACE OF WORK

The place of work must be cleaned and tidied up; do not place knives, rags or other things under the machine base.

2.6 WORK DRESSES AND PERSONAL PROTECTIONS

Anybody who uses this machine must wear close-fitting and clean dresses according to hygienic rules.

When blade maintenance and cleaning are carried out, it is important to use wrist protection gloves.

2.7 MAIN SAFETY DEVICES

- Blade ring guard : it safeguards blade rim along all the circle part which is not used to cut.
- Food-pusher, platform guard knob: they restrict contact risk with blade near the cutting area.
- Electric installation: all voltaged parts are insulated.
- Safety device to stop the rotation of the blade if the clamping handle of the blade guard is released.

 Daily check before starting work, or after a maintenance intervention that all safety devices are working right.
In case of danger switch off the machine by acting on the switch and disconnect plug.
Periodically check feeding cable integrity.

 It is forbidden taking off, changing or making useless safety devices.

6 CLEANING AND MAINTENANCE

6.1 CLEANING

 Disconnect the machine from current tap and check that regulator knob is on home position, before starting with cleaning.

Cleaning must be carried out at least once a day.

Do not use abrasive materials, poisonous cleanings, based on soda or chlorine; besides avoid water and steam spouts.

Use a damp cloth and PH neuter dish detergent; remove any kind of detergent remainders before using the machine.

Check that the machine is fully dry before connecting it to the current outlet.

To complete the cleaning operation of platform proceed as follows: pull the carriage at the beginning of the stroke; set the thickness control knob to "zero"; unscrew the knob (40); tilt the product-holder platform. Once the cleaning operation is complete position the platform back to its normal position and screw the knob again.

To clean the central part of the blade and the blade cover disassemble the blade cover by unscrewing the blade cover knob.

 Disassembly of the blade and of platform is an extraordinary service requiring skilled personnel intervention. Blade can be disassembled by unscrewing the 3 screws locking it and by lifting it up from its seat.

6.2 LUBRICATION

Lubricate at least once a month, and food-pusher shaft using paraffin oil.

6.3 SHARPENING

 Carry on with blade sharpening after checking that machine is switched off and after carrying out its cleaning.

 It is necessary that blade is cleaned and grease is very well removed.

Ensure that the machine is turned off, after untightening knob, lift the sharpening unit up, turn it clockwise at 180° and lock it by screwing the knob. Turn the machine on to start the sharpening process and push simultaneously the push-button in order to actuate the sharpening stone. Duration of the sharpening process should be 30 seconds approximately. To eliminate the deburring push the deburring stone push-button for approximately 2 seconds. Turn the machine off and bring the sharpener back to its original position.

4.2 INSTALLATION PLACE REQUIREMENTS

The plane on which the machine is installed must be stable, not inclined, balanced, at a right height in order to obtain a right work position. Bearing surface sizes must take machine overall dimensions shown in the chapter "Technical Data" into consideration.

Working area must be dry, away from heating sources and from passing gangways; it must allow an easy normal machine use, cleaning and maintenance.

4.3 ELECTRIC CONNECTION

The machine has a feeding cable to be connected to a fixed plug with breaker and with magnetothermic protection.

Make sure that mains voltage is equal to that one shown on machine identification shield.

After checking machine is all right, drive the breaker to turn the blade.

5 MACHINE USE

5.1 FORESEEN USE

The machine must be used to cut eatable products with sizes which are in relation to cutting capacity shown in chapter "Technical Data" and with a weight that does not endanger its balance.

Frozen products are not foreseen, as well as those ones with bones or too much seasoned.

5.2 CUTTING

 Before machine starting always check right working safety devices and machine cleaning.

 Before product loading or unloading on the platform, check that regulator knob is on home position and that blade is at a standstill.

Bring the platform at starting position, towards operator; lift the food-pusher and put the product to be cut on the platform, in contact with the regulator plate stop product with food-pusher, turn regulator knob till to obtain the required thickness; press the switch to start the blade; by seizing knob with the right hand make the platform slide by alternating movement and carry out cutting.

Pick up slices in their exit area.

When cutting is finished, switch the machine off by operating the switch and place again regulator knob on home position.

3 TECHNICAL DATA

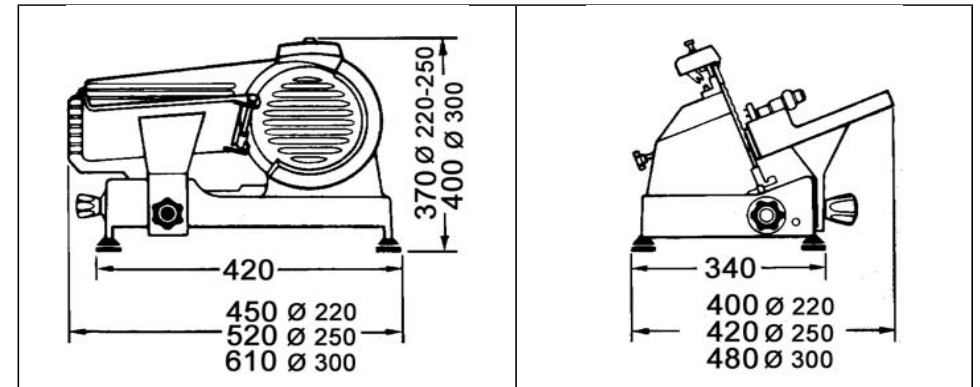



Blade	Cut thickness	Cut capacity	Power	Net weight
220 mm	13 mm	210x135 mm	0,10 kW	13
250 mm	13 mm	210x150 mm	0,14 kW	16
300 mm	13 mm	240x190 mm	0,14 kW	20

4 INSTALLATION

4.1 TRANSPORT

At machine receipt check that packing is complete. All packaging components are classified as solid urban waste; do not dispose of them in the environment.

 complaints in case of failures occurred during transport must be made known to shipping agent; the machine travels at buyer risk. Take the machine out of the packaging by seizing it by its base; machine weight is specified in the chapter "Technical Data".

 Check that regulator knob is on home position.

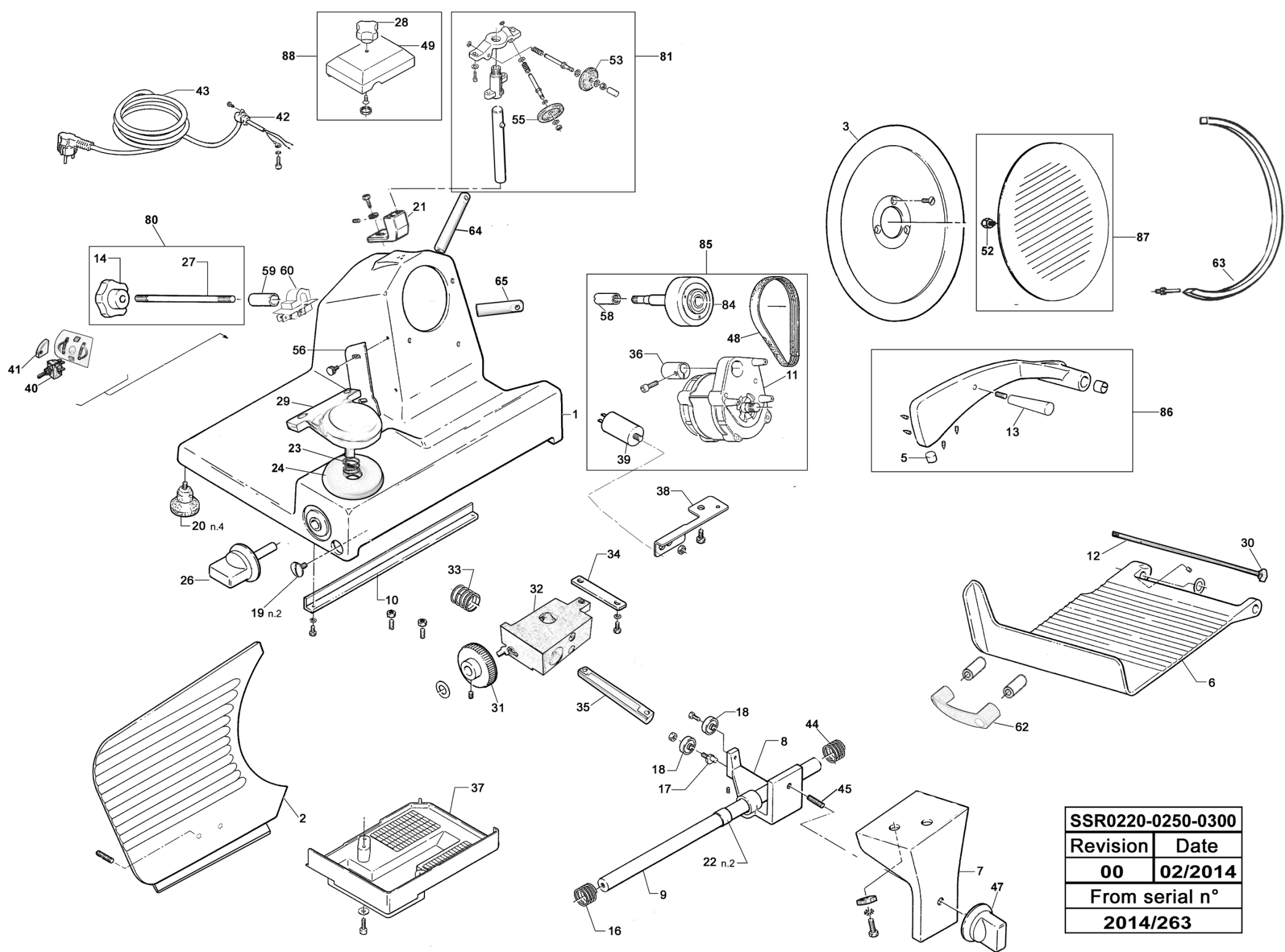

SSR0220-0250-0300	
Revision	Date
00	02/2014
From serial n°	
2014/263	