



CUTTER-EMULSIFIER KE-5V 230/50-60/1 AUS

Cube capacity: 5.5 litres. Variable speed.



P/N 1050838



DYNAMIC PREPARATION
CUTTER-MIXERS & EMULSIFIERS

SALES DESCRIPTION

To cut, grind, mix and knead any food in seconds.

Brushless technology: maximum efficiency.

FEATURES AND BENEFITS

Equipped with “brushless” technology: powerful and efficient motors.

- ✓ Maximum efficiency: maintain the torque throughout the speed range.
- ✓ Exclusive “force control system”: guarantee of a uniform and high quality result.
- ✓ Lightweight and compact design: they weigh less, they occupy less space.
- ✓ Improved air/water-tightness since no ventilation is required.
- ✓ They generate less noise: improved workplace environment.

Efficiency and performance

- ✓ Possibility of programming by time and pulse button.
- ✓ Reverse function, ideal for mixing products instead of cutting.
- ✓ 5.5 litre stainless steel hopper.
- ✓ Polycarbonate lid with built-in “cut&mix” mixer.
- ✓ Depending on the purpose, the possibility of using optional smooth or perforated blades.

Built to last

- ✓ Robust construction of stainless steel and food-grade materials of the highest quality: stainless steel motor block with aluminium lid. Stainless steel hopper with highly-resistant polycarbonate lid.

Maximum comfort for the user

- ✓ Advanced control panel that is very intuitive to use and offers all the information at a glance.

Maintenance, safety, hygiene

- ✓ Safety microswitches on the hopper and lid position.
- ✓ Appliance certified by NSF International (regulations on hygiene, cleaning and materials suitable for contact with foods).
- ✓ 100% tested.

INCLUDES

- ✓ Set of micro-serrated blades.
- ✓ “Cut&mix” mixer

ACCESSORIES

- Blades for CK/CKE
- “Cut&Mix” Scrapers CK/CKE



sammic | www.sammic.com
Food Service Equipment Manufacturer

Polígono Basarte, 1. phone +34 943 15 72 36
20720 Azkoitia, Spain sales@sammic.com



Project	Date
Item	Qty
Approved	

product sheet
updated 04/10/2019



CUTTER-EMULSIFIER KE-5V 230/50-60/1 AUS

Cube capacity: 5.5 litres. Variable speed.



P/N 1050838

SPECIFICATIONS

Crated dimensions

440 x 355 x 570 mm

: 0.09 m³

Gross weight: 23.5 Kg.

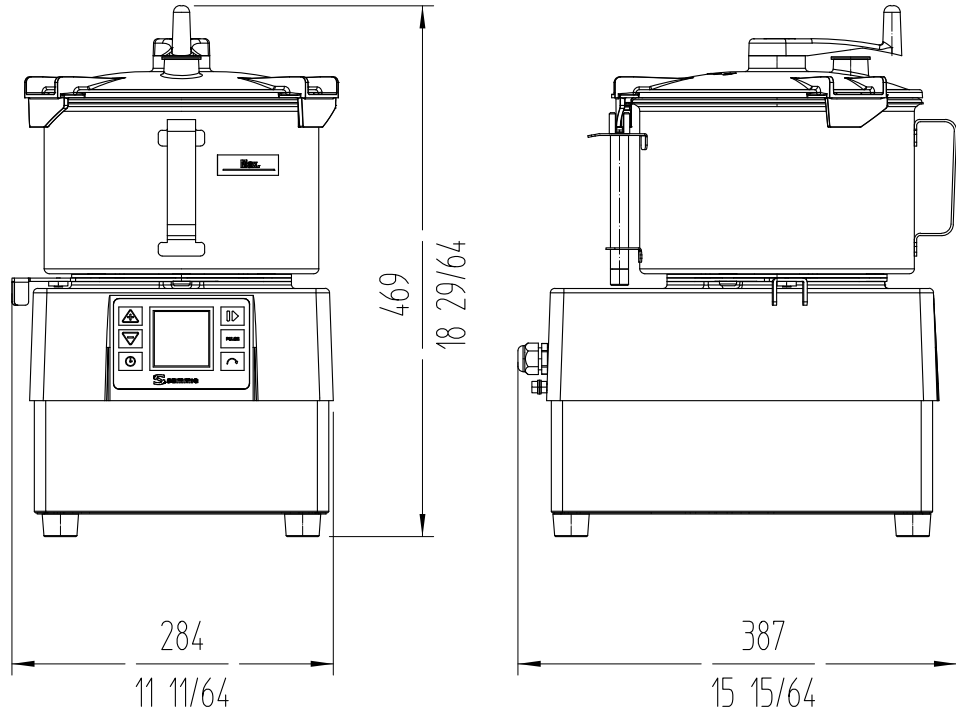

DYNAMIC PREPARATION
CUTTER-MIXERS & EMULSIFIERS

sammic | www.sammic.com
Food Service Equipment Manufacturer

Polígono Basarte, 1. phone +34 943 15 72 36
20720 Azkoitia, Spain sales@sammic.com



Project	Date
Item	Qty
Approved	

product sheet
updated 04/10/2019