

HNC-180BE-R-B COUNTER SHOWCASE



<i>Product Specifications</i>	
<i>EXTERIOR DIMENSIONS</i>	Width: 1800mm Depth: 345mm Height: 270mm
<i>INTERIOR DIMENSIONS</i>	Width: 1445mm Depth: 288mm (floor) Height: 157mm
<i>WEIGHT</i>	Net: 42kg Packed: 60kg
<i>AC SUPPLY VOLTAGE</i>	220 - 240V / 50Hz 10Amps
<i>SATURATION TEMPERATURE</i>	Approx 4°C (Ambient temp 27°C, no load)
<i>NET CAPACITY</i>	72L
<i>AMBIENT TEMPERATURE</i>	10°C - 30°C
<i>REFRIGERATION SYSTEM</i>	Convection Cooling

<i>Product Range</i>		
<i>PART NO.</i>	<i>DESCRIPTION</i>	<i>LIST PRICE</i>
91000037	HNC-180BE-R-B	\$4505.00



HNC-180BE-R-B COUNTER SHOWCASE

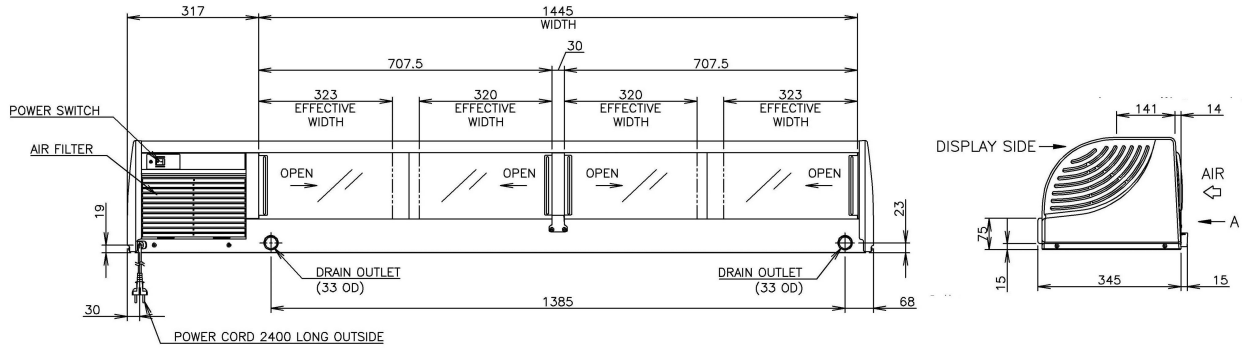

VIEW A(REAR)

