



## HCT102E

Refrigerated holding  
trolley (positive)

### CONSTRUCTION FEATURES

- Chamber with radiused corners and removable side racks to facilitate cleaning
- All-around rubber bumpers
- Highly efficient and thick insulation, casing injected with CFC-free polyurethane foam
- Ergonomic and fully built-in door handles with magnetic closure
- Cooling through air-cooled evaporator
- Ecological type compressor unit (R404A)
- Mounted on four 150mm diameter castors, two of wich with brake
- Ergonomic handles for pushing and guiding
- Easy access to facilitate maintenance and repair

### FUNCTIONAL FEATURES

- Electronic temperature control with defrosting programme
- Simplified, user-friendly controls
- Operating temperature +0°C / +5°C
- Condensate evaporation tray

### STANDARD SUPPLY

- Removable GN2/1 and GN1/1 tray racks

### OPTIONS & ACCESSORIES

- Stainless steel plate baskets

**MODULINESRL**

Via dell'Industria 11, Z.I. San Giacomo di Veglia 31029 Vittorio Veneto (TV) - ITALY  
 tel. +39 0438 5063 - fax +39 0438 912 323 - info@moduline.it - www.moduline.it



# moduline

## TECHNICAL INSTALLATION DIAGRAM

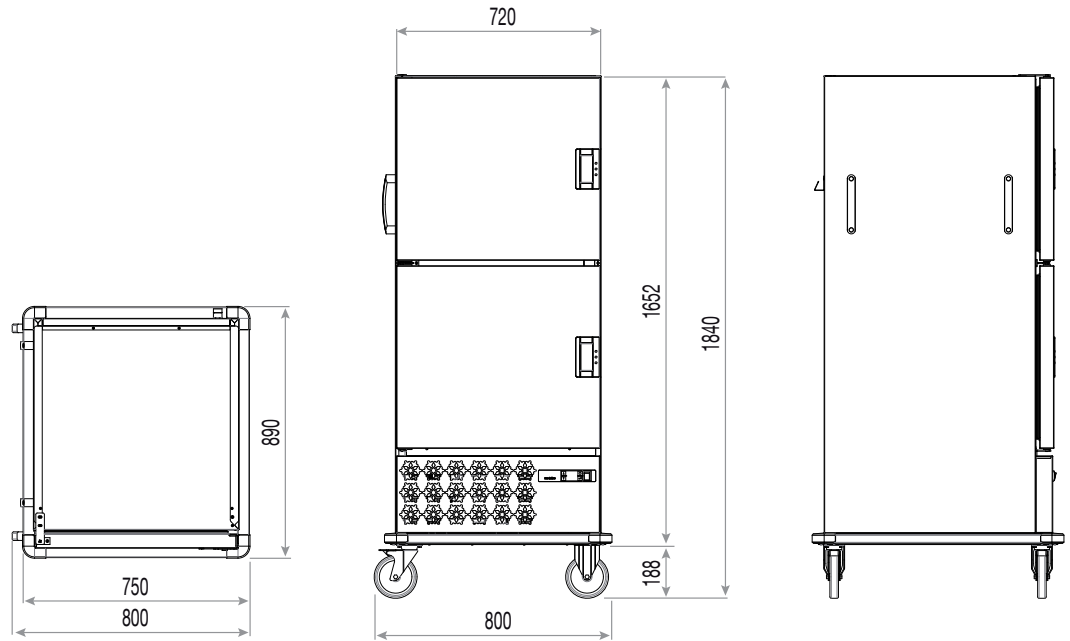

Overall dimensions (W x D x H) - mm	800 x 890 x 1840
Trays capacity	10 x GN 2/1 20 x GN 1/1
Plates capacity plates $\varnothing$ 230-310 containers GN 1/2	32
Power kW	0,65
Power supply	AC 230 V / 50 Hz

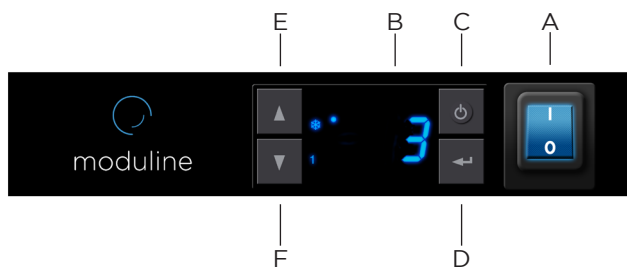

- A ON/OFF switch
- B Display
- C Functions key
- D Enter key
- E Temperature increase key
- F Temperature decrease key

### MODULINESRL

Via dell'Industria 11, Z.I. San Giacomo di Veglia 31029 Vittorio Veneto (TV) - ITALY  
tel. +39 0438 5063 - fax +39 0438 912 323 - info@moduline.it - www.moduline.it