

# Polariz

## Instruction Manual Polariz Refrigerator

### 1. Preface

**This instruction manual provides all the necessary information regarding:**

- Use of the refrigerator
- Technical specifications
- Installation and handling
- Operation procedures and instructions
- Maintenance operation

The manual is to be considered an integral part of the refrigerator and should be stored in a safe place for further consult to permit a good working life of the refrigerator.

**\*\*ATTENTION\*\***

**The manufacturer cannot be held liable in the following cases:**

- Improper installation (not in accordance with the guidelines indicated herein)
- Misuse of the refrigerator
- Power supply defects
- Improper or inadequate maintenance.
- Unauthorized modification or tampering
- Use of non-original spare parts
- Partial or total failure to comply with the instructions

**!! All electrical equipment can be hazardous to health. Current standards and legal requirements must be complied with during the installation and use of any equipment.**

### 2. Use of the equipment

The refrigerator are preserving fresh perishable foodstuffs, with an in-built refrigerated unit.

The operating temperature for refrigeration is:

- Between +2°C and +8°C at room temperature of +43°C an 60%RD.

The operating temperature for frozen food maintenance is:

- Between -15°C and -18°C at room temperature of +43 °C an 60% RD.

### 3. Technical features

The refrigerator is a ventilated system, the evaporator is in a separate insulated box on the top. All the materials used in the manufacture of this unit are guaranteed to be suitable for use with foodstuffs. The gases used in refrigerator is R404a for freezer, R134A/R22 for chiller

The refrigerating circuit are in compliance with current normative.

### 4. Operation

The gas in the refrigerating circuit is in the first time compressed, liquefied and then evaporated in the ventilated evaporator, situated on the top of the container.

This cycle involves the absorption of heat from the air in the refrigerator compartment and the reason is cooled. The heat produced is then dissipated to the outside environment by a condenser unit located on the top of the refrigerator.

### 5. Control unit

The refrigerator is commanded from a “digital control unit” in the top panel of the refrigerator.

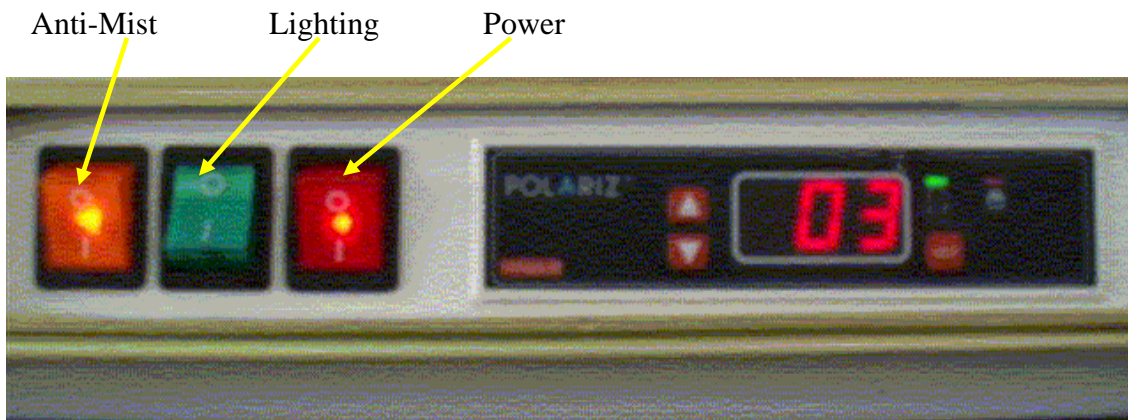

For Display Chiller



For Upright & Under counter Chiller

Technical data

- **12~24V/AC/DC/50/~60HZ**
- **Working temperature -15°C ~ +70°C**
- **Resolution 1°C**
- **Relay rating 30A/240V**  
(Resistance load)
- **Fit-in size 137\*32\*28mm<sup>3</sup>**
- **Temperature range -50°C ~ +90°C**
- **Accuracy Within 1% of full scale**
- **Display 3 X Seven segment LEDS**
- **Mounting SNAP-IN**

### List of parameter

No	Symbol	Description	Range	Default
1.	tS	Set compressor stop temperature	-50°C ~ +90°C	5°C
2.	td	Define differential temperature	1°C ~ +15°C	4°C
3.	Sd	Compressor start time delay after stop	0 ~ 15Min	1 Min
4.	di	Defrost interval time	0 ~ 24 Hr	6 Hr
5.	dd	Defrost duration time	0 ~ 60 Min	15Min
6.	ta	Sensor calibration	-15°C ~ +15°C	°C

### List of Lock system parameter

No.	Symbol	Description		Default
1.	LO	Select system parameters to lock or unlock	y:lock/n:lock	N
2.	tH	The upper temperature limit	Ts ~ +90°C	+50°C
3.	tL	The lower temperature limit	-50°C ~ +tS	-50°C

### Error Code

Error code	
E1H	Sensor shorted or temperature higher than 90°C, E1H flashing.
E1L	Sensor opened or temperature lower than -50°C, E1L flashing.

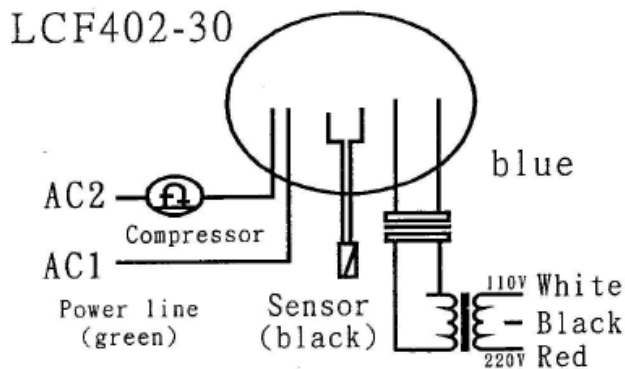

### Access to Lock System Parameter

1. Press set button. The screen will flash 888.
2. Press the Up & Down buttons together and it will show LO. symbol.
3. Please select n if you wish to unlock the parameter.

### Access to the System Parameter

Please take note: It is only accessible if you have unlock the system (LO).

1. Press SET button and the screen will 888. for 5 times.
2. After that, the screen will show the first system parameter **tS**.
3. You can press up & down button to modify the value.
4. After each modification, press SET button to go to next parameter.

Specification of Parameter Setting

1. You can press UP & DOWN buttons to modify the value. After each modification, press SET Button to go to next parameter.
2. If no key is pressed during the next 8 seconds, the controller will automatically finish the setting procedure.

**\*Please take note:** Any modification on the parameter must be consulted by trained technicians

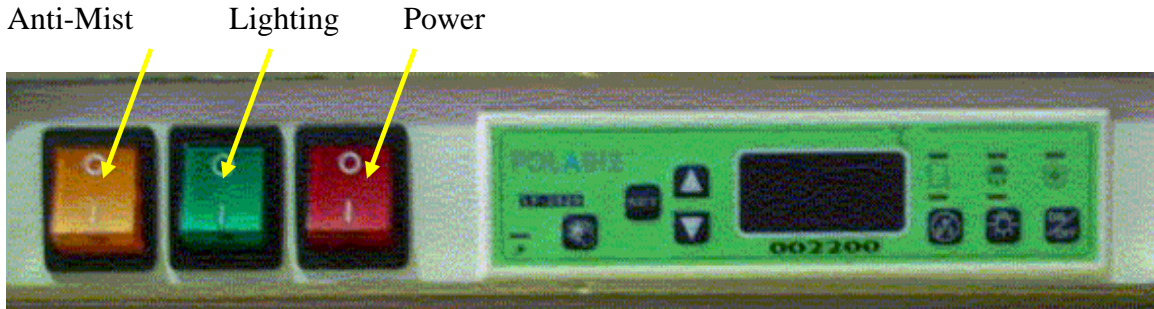

**For Display Freezer**



**For Upright & Under counter Freezer**

Technical data

- **90~240V/AC/DC/50/~60HZ**
- **Sensor type: NTC**
- **Resolution: 1°C**
- **Working temperature -15°C ~ +70°C**
- **Compressor Relay power rating 30A/250V (Resistance load)**
- **Heater Relay power rating 10A/250V (Resistance load)**
- **FAN/LAMP/DEFOG Relay power rating 8A/250V ( Resistance load)**
- **Dimension: 137\*28\*32mm<sup>3</sup>**
- **Temperature range -50°C ~ +50°C**
- **Accuracy Within 1% of full scale**
- **Display 3 X Seven segment LEDS**
- **Mounting SNAP-IN**

List of parameter

No	Symbol	Description	Range	Default
1.	tS	Set compressor stop temperature	-50°C ~ +50°C	-17°C
2.	td	Define differential temperature	1°C ~ +15°C	4°C
3.	Sd	Compressor start time delay after stop	0 ~ 15Min	1 Min
4.	dt	Defrost type	EL/HS	EL
5.	di	Defrost interval time	0 ~ 24 Hr	4 Hr
6.	dd	Defrost duration time	0 ~ 60 Min	20Min

7.	dS	Defrost stop temperature	-20°C ~ +50°C	25°C
8.	FS	Fan start temperature	-30°C ~ 50°C	0°C
9.	Fd	Fan delay after defrost	0 ~ 60 Min	3 Min
10.	CL	Condenser cleaning time interval	0 ~ 180 day	0 day
11.	tA	Sensor calibration adjustment	-10°C ~ 10°C	0°C

List of Lock system parameter

No.	Symbol	Description		Default
1.	LO	Select system parameters to lock or unlock	y:lock/n:lock	N
2.	tH	The upper temperature limit	Ts ~ +90°C	+50°C
3.	tL	The lower temperature limit	-50°C ~ +tS	-50°C
4.	AH	High temperature alarm	ts~50°C	30°C
5.	Ht	High temperature alarm time	30~180Min	90Min
6.	AL	Low temperature alarm	-50°C~ts	-30°C
7.	Lt	Low temperature alarm time	0~180Min	10Min
8.	FL	Fan working type	y:stop/ n:run	n
9.	FP	Fan stop time(option for FL=Y)	0~60Min	2Min
10.	FU	Fan run time(option for FL=Y)	0~60Sec	15Sec
11.	tC	Defrost interval time type	ti/tp	ti
12.	HP	High pressure detect	y(detect)/ n(no detect)	n
13.	rt	Temperature up delay time	0~180sec	10sec

Error Code

Sensor Error	Error code	Description
	E1H	Sensor shorted or temperature higher than 50°C, E1H flashing.
	E1L	Sensor opened or temperature lowerer than -50°C, E1H flashing.
Evaporator Sensor Error	E2H	Evaporator sensor shorted or temperature higher than 50°C, E2H flashing.
	E2L	Evaporator sensor opened or temperature lower than -50°C, E2L flashing.
	CLn	Condenser need to be clean, CLn flashing

**Function keys :**

**Indicators :**

Symbol	Name	Function description	Symbol	Color	Description
	Power on/off	The controller power supply key		Yellow	Lamp on, power supply
	Increase/Decrease	To increase or decrease one unit value		Green	Lamp flash, compressor time delay Lamp on, compressor running
	Set	Request for setting the parameter		Red	Lamp on, system defrosting
	Manual defrost	Push this key to do manual defrost		Yellow	Lamp on, fan is running Lamp flash, fan is ready, but waiting to run
	Door heater	To on/off the door heater for clarify the showcase door		Yellow	Lamp on, door heater is on
	Light	To on/off the indoor light appliance		Yellow	Lamp on, indoor light appliance is on

**Wiring Diagram**

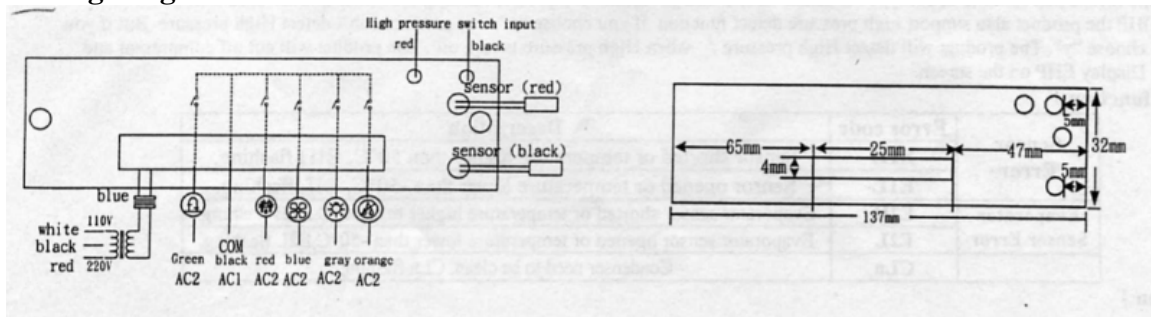

**Access to Lock System Parameter**

1. Press set button. The screen will flash 888.
2. Press the Up & Down buttons together and it will show LO. symbol.
3. Please select n if you wish to unlock the parameter.

**Access to the System Parameter**

Please take note: It is only accessible if you have unlock the system (LO).

1. Press SET button and the screen will 888. for 5 times.
2. After that, the screen will show the first system parameter tS.
3. You can press up & down button to modify the valve.
4. After each modification, press SET button to go to next parameter.

**Parameter Setting**

1. You can press UP & DOWN buttons to modify the value. After each modification, press SET Button to go to next parameter.
2. If no key is pressed during the next 8 seconds, the controller will automatically finish the setting procedure.

## 6. Handling

The refrigerator arrive in PET film .

**!!The refrigerator must be transported and handled with care to avoid posing a hazard to persons or property. Never place a refrigerator with an in-built refrigerated unit on its side or turn it upside down as this may damage or impair operation of the refrigerated unit. We will not held liable for any damage or defects arising directly or indirectly from improper handling of the equipment or non-compliance with the safeguards illustrated above.**

## 7. Installation procedure

- a) Place the refrigerator in the coolest and best ventilated part of the room. Don't install the refrigerator in the near of heat and direct sunlight sources.
- b) Remove the straps securing the cardboard packing
- c) Remove the cardboard covering (optional).
- d) Remove the PET protection film
- e) Clean the refrigerator with mild detergent and then dry it with a soft cloth.

## 8. Connecting to the main power supply!!

**This operation must be carried out by professionally and qualified persons.**

The refrigerator are supplied complete with a power supply cable for the connection to the main power supply. A thermomagnetic circuit breaker (not supplied) must be installed between the mains power point and the power supply cable of the refrigerator.

**Before proceeding make sure that:**

- the mains voltage corresponds to the voltage on the refrigerator 240V/50Hz/1Ph; to ensure proper operation it is essential for the power supply voltage to come within a range of +/- 6% of the unit's rated voltage
- the electric system to which the refrigerator is sized to cater for the rated electric output of the buffet unit being installed
- the electronic system to which the refrigerator is connected is made in compliance with current standard requirements
- the electric connections and the installation of the thermomagnetic circuit breaker have been done by qualified person.

Connecting steps: 1. Install a thermomagnetic circuit breaker suited to the rated output of unit being installed 2. Connect the refrigerator unit to the thermomagnetic circuit breaker outlet 3. Check that the refrigerator is in order as demonstrated by the light incorporated in the main switch coming on.

## 9. Maintenance instructions

The smooth operation and life of the equipment are mainly determined by correct and regular maintenance

**!! Disconnect the refrigerator power supply cable from the mains prior to carrying out any type of cleaning operation.**

## 10. Cleaning

Regular cleaning of the refrigerator unit is strongly recommended each month. Please follow the instructions below.

**!! Disconnect the refrigerator power supply cable from the mains prior to carrying out any type of cleaning operation.**

## 11. Cleaning the refrigerator surface

Clean the refrigerator with mild detergent and then dry it with a soft cloth.

**Do not use abrasive detergents!**

## 12. Cleaning the inside of the refrigerator

Clean the inside area min. each month with a detergent suitable for use with foodstuffs.



## 13. Cleaning the condenser

For an efficient operation of the refrigerator it is advisable to clean the condenser regularly approx. once a month with a dry brush or vacuum cleaner.

## 14. Troubleshooting

- 1) Refrigerator stops working
  - i) Power supply failure

Remedies:

- (i) Check that the plug is inserted properly in the socket
  - (ii) Check that the switch on/off
  - (iii) Check that the mains voltage powers the plug
- 2) Refrigerator temperature go up
  - (i) Unit too near to a heat source
  - (ii) Condenser is dirty



Remedies:

- (iii) Move the counter or the heat source further away
- (iv) Clean the condenser

### **15. Technical service**

For technical service please contact the dealer technical department and give him the serial n°, and the date of buy.

#### **\*Take note**

**Polariz reserve the right, without notice, to make changes and revisions to the instruction manual, which in our opinion, will provide better performance, durability and efficiency.**