



Catalogue
CATERING

Chapter
COOKING

Model
F-E9115 380...415V 3N 50/60Hz 1C

19020767

DIMENSIONS

	Article		Packed	
Lenght	400	mm	440	mm
Depth	930	mm	1022	mm
Height	850	mm	1115	mm
Weight	75,000	kg	90,000	kg
Volume	0,361	m3	0,501	m3

ELECTRICITY

Electric power	12,00	kw
Voltage	380...415V -3N	
Three-phase +N 400V wiring	4X2,5MM2+T	
Frequency	50/60	hz

ELECTRIC DEEP FAT FRYER, F-E9115

Fryers are designed to deep fry large amounts of product (chips, croquettes, different types of dredgings, etc.).
2 mm stainless AISI-304 steel top with rounded edges for easy cleaning.
Laser cut and automatic welding for a perfect adjustment of sides between modules with square angle finish.

Number of wells: 1.

Well capacity: 15 litres.

Standard equipment: One 250x287x108 mm basket.

Well integrated in the top, with cool area at the bottom. This helps to maintain oil properties and quality for a longer time.

Heating by means of AISI 304 stainless steel electrical resistances inside the well. They can be tilted more than 90° for a perfect cleaning.

High power/litre rate: 0.8 kW per litre.

Thermostat for temperature control (between 60 and 200°C).

Safety thermostat.

Oil discharge through robust and reliable high temperature resistant ball tap.

Fitted with independent lids for each well.

Basket drainage support at the back of the well.

Water-tight and protecting-support controls.

High temperature protector for the chimney made of enamelled cast iron.

Front access to components.

According to European standards for components and panels temperature, efficiencies and combustion, and sanitary regulations (EN-60335 and EN-203)

IPX5 grade water protection equipment.

Maximum power: 12.0 kW.

Dimensions: 400 x 930 x 850 mm.



FAGOR INDUSTRIAL

Catalogue
CATERING

Chapter
COOKING

Model
F-E9115 380...415V 3N 50/60Hz 1C

19020767

F-E9115 & F-E9121

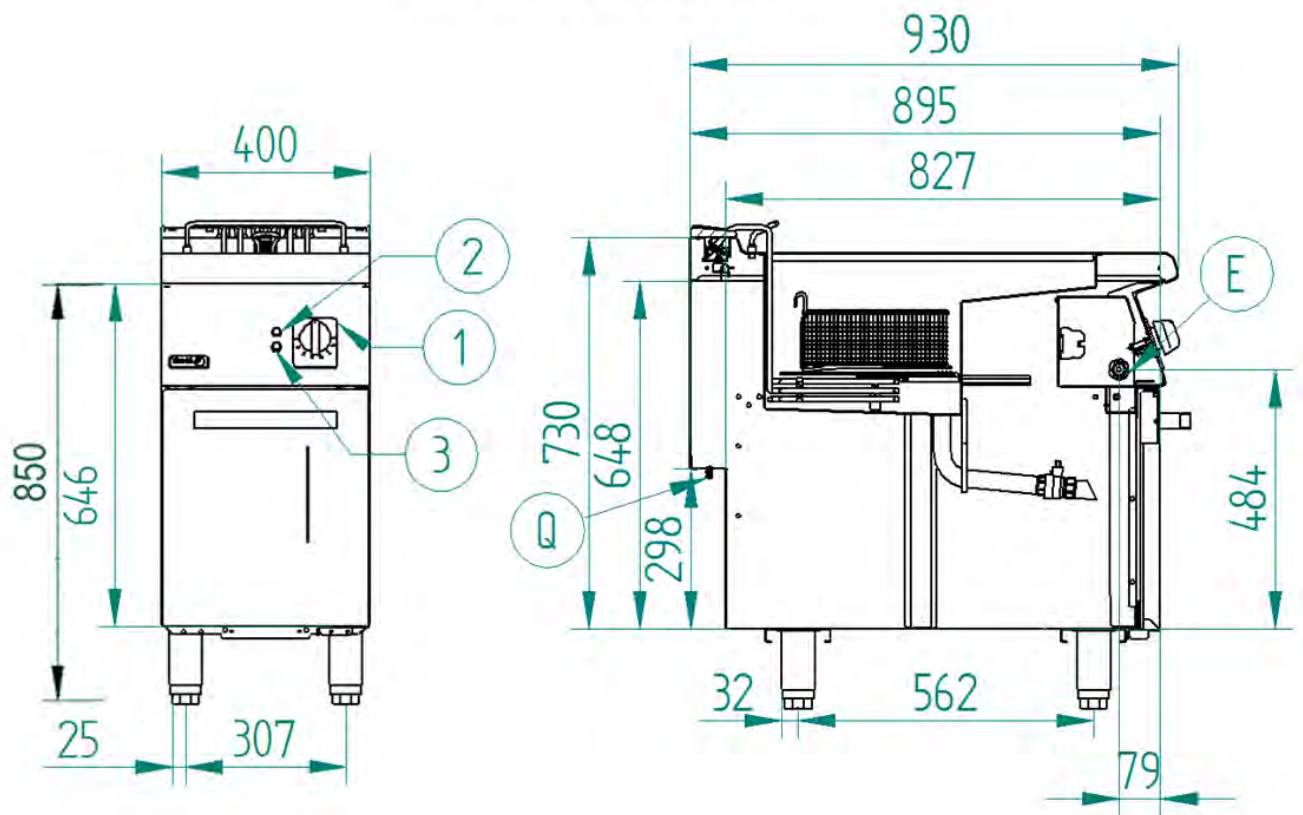

E – Conexión eléctrica
Q – Conexión equipotencial
1 – Mando termostato
2 – Piloto verde
3 – Piloto ambar

Electrical connection
Equipotential connection
Thermostat control
Green pilot
Ambar pilot