



Infrared Conveyor Ovens

Job _____ Item# _____

Conveyor Oven Model DZ33I with Menu Select®



Model DZ33I
Shown with Optional Split Belt

the conveyor belt. When food product is placed on the conveyor belt, it cooks as it passes between the top and bottom emitters. Oven operates coolly, quietly and requires minimal ventilation.

Controls

The oven is controlled by a microprocessor, which includes a time/date clock for automatic turn "ON" and turn "OFF", an energy-conserving standby mode. The oven has a power circuit breaker and a manual "ON/OFF" switch.

MenuSelect®

The patented MenuSelect® feature allows the operator to preset up to ten (10) different time and temperature combinations into the control that can be recalled by pressing the appropriate preset key, then the computer automatically adjusts time (belt speed) and temperatures. A ready message is displayed when the desired temperatures are reached.

Warranty

Warranted for one year covering parts and labor under the "No Quibble" warranty. USA only.

Electrical Ordering Information

- 208VAC, 1-Phase or 3-Phase
- 240VAC, 1-Phase or 3-Phase
- 230VAC, 3-Phase CE
- 380VAC, 3-Phase CE
- 400VAC, 3-Phase

*Consult the electrical data on the rear side of this specification sheet for connected kW and amperage loading representing your local utility.

Application

CTX conveyor ovens are designed to cook, bake or broil in high volume with consistent quality results.

Standard Features:

- Self-cleaning
- Electronic touch control
- Temperature range 200F to 900F
- Belt speed from 1 to 60 minutes
- Manager control lockout
- Belt direction electronically controlled through keypad
- Separate left and right bottom and top heat zones
- Entrance and exit trays

Options:

- 50/50 Split Belt

General Information

Heavy-duty, electric, conveyor ovens consist of a cooking chamber, equipped with 18" wide stainless steel chain link belt. Overall dimensions are 59"W by 39-1/8"D by 17-15/16"H. Oven chamber is 31"W by 22-1/4"D by 5 1/2"H. Ovens may be stacked three high on a short base.

Construction

The outer body is constructed with 18-gauge stainless steel. The oven chamber is constructed of 16-gauge aluminized steel. Infrared heat emitters are enclosed in high-strength thermal conductive steel plates that form the upper and lower housing of the oven chambers.

Insulation

The oven is fully insulated on all four sides and top with high temperature insulation.

Electrical

Ovens can be ordered for 208VAC, 240VAC, 230VAC, 380VAC or 400 VAC electrical utilities. The ovens are wired for either 1-phase or 3-phase electrical connection on 208 and 240VAC. Ovens can be field converted to single phase. Electrical cord knock-out is provided on the lower left-hand rear side panel of the oven. An access panel on the rear of the oven available for making electrical connections.

Heating

Heating is accomplished with four (4) infrared emitters. Two infrared emitters are located above and below



A MIDDLEBY COMPANY
1400 Toastmaster Drive
Elgin, Illinois 60120 USA
(847) 741-3300 Fax: (847) 741-0015
www.middleby-marshall.com
www.ctxautomation.com



Conveyor Oven Model DZ33I with Menu Select®

NOTE: ALL FIGURES IN PARENTHESES ARE IN MILLIMETERS.

We reserve the right to change specifications and product design without notice. Such revisions do not entitle the buyer to corresponding changes, improvements, additions or replacements for previously purchased equipment.

TOP VIEW

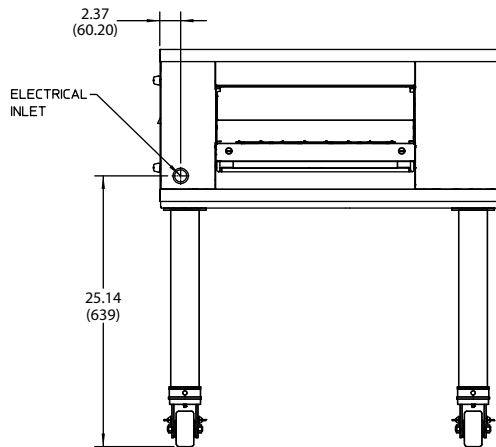
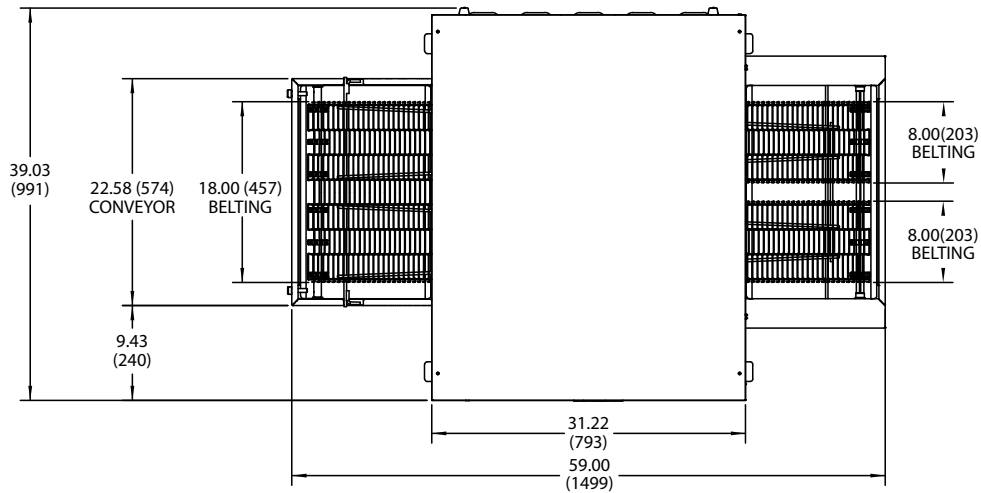

SIDE VIEW

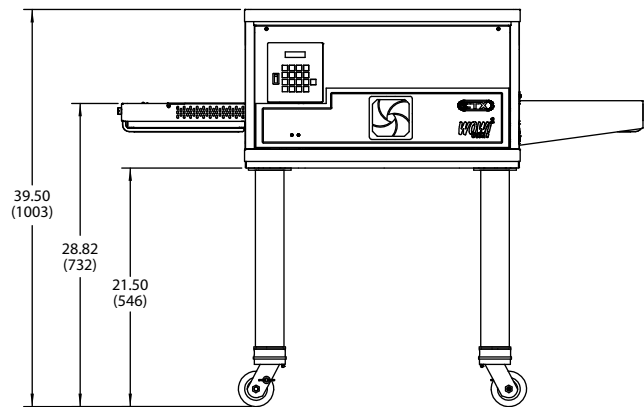

FRONT VIEW



Conveyor Oven Model DZ33I with Menu Select®

NOTE: ALL FIGURES IN PARENTHESES ARE IN MILLIMETERS.

We reserve the right to change specifications and product design without notice. Such revisions do not entitle the buyer to corresponding changes, improvements, additions or replacements for previously purchased equipment.

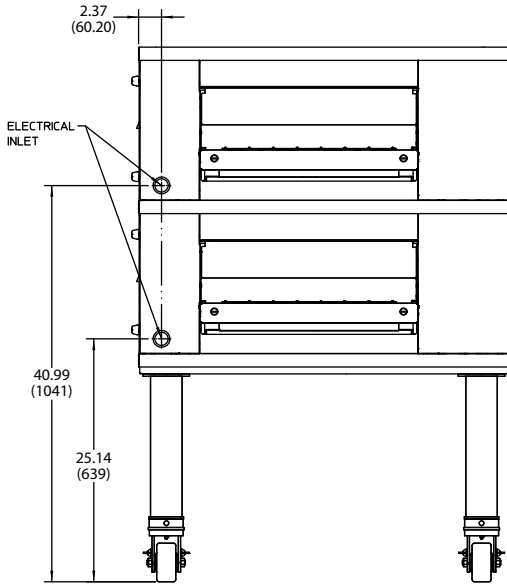

SIDE VIEW

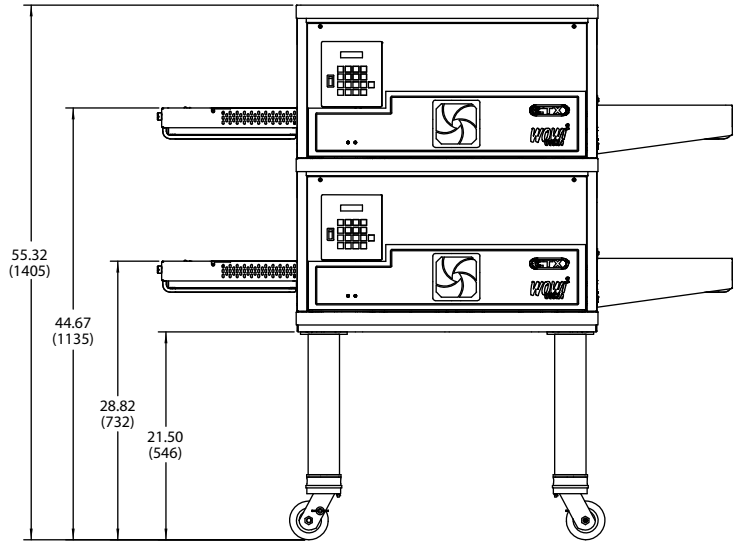

FRONT VIEW

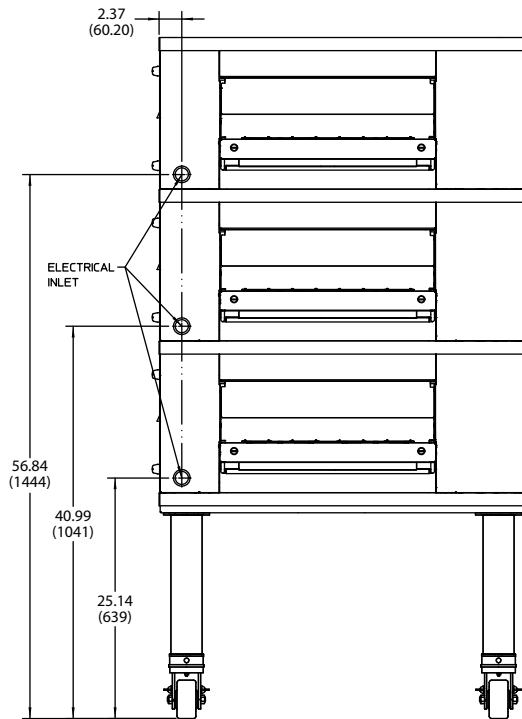

SIDE VIEW

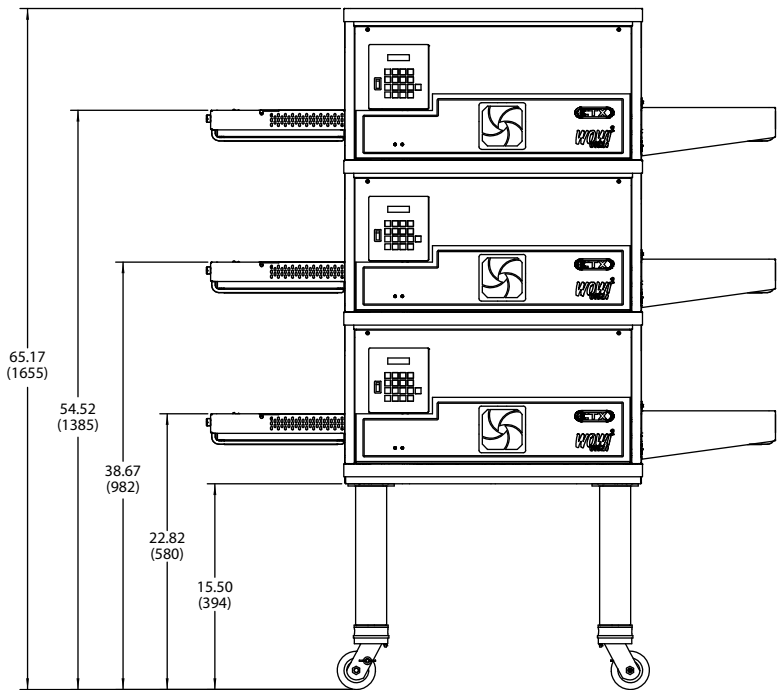

FRONT VIEW



Conveyor Oven Model DZ33I with Menu Select®

NOTE: ALL FIGURES IN PARENTHESES ARE IN MILLIMETERS.

We reserve the right to change specifications and product design without notice. Such revisions do not entitle the buyer to corresponding changes, improvements, additions or replacements for previously purchased equipment.

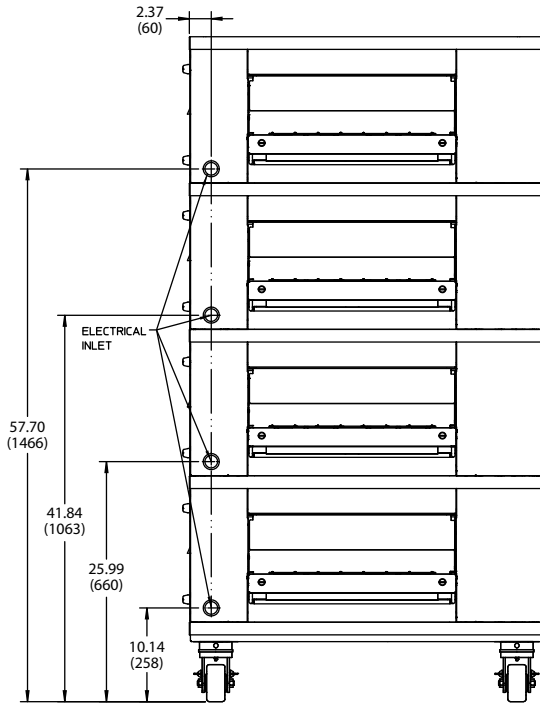

SIDE VIEW

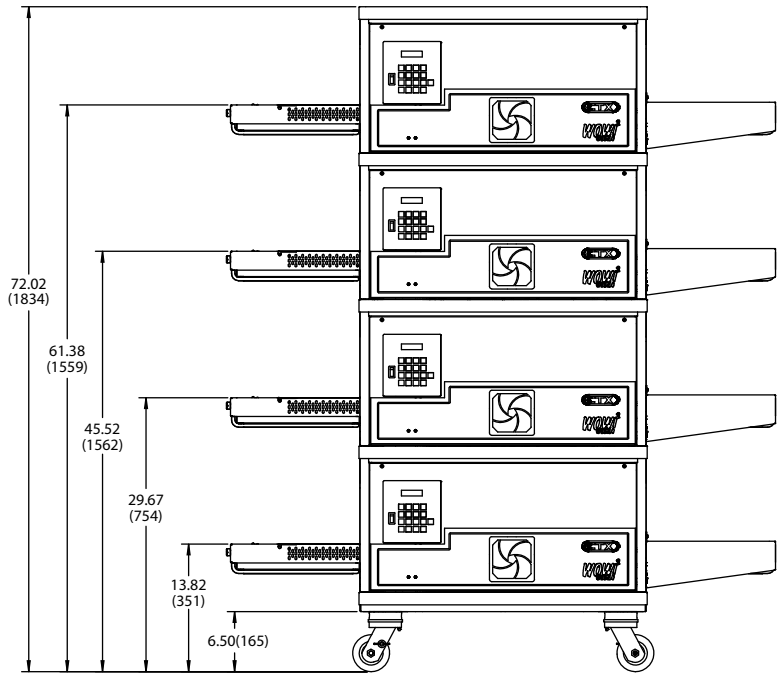

FRONT VIEW

RECOMMENDED MINIMUM CLEARANCES

Rear of Oven to Wall - 0"

Left Side of Oven to Wall - 4"

Right Side of Oven to Wall - 4"

ELECTRICAL DATA - One Power Supply

MODEL NO	AC VOLTS	PHASE	Hz	CONNECTED kW	AVG OPERATING kW	CONNECTED LOAD (AMPS)				REQUIRED BREAKER (AMPS)
						L1	L2	L3	N	
DZ33I	208*	1	50/60	7.7	4.7	32.0	32.0	--	--	35*
DZ33I	208*	3	50/60	7.5	4.7	26.0	26.0	19.0	--	30*
DZ33I	240*	1	50/60	7.6	5.0	28.0	28.0	--	--	30*
DZ33I	240*	3	50/60	7.9	5.0	23.0	23.0	17.0	--	25*
DZ33I (CE Listed)	230	3	50/60	6.9	5.0	22.0	22.0	16.0	--	30
DZ33I (CE Listed)	380	3	50/60	6.8	5.0	18.0	9.0	9.0	9.0	25
DZ33I	416	3	50/60	7.7	5.0	19.0	10.0	10.0	10.0	25

* Note: US Domestic Ovens - a 6ft cord and NEMA 15-30P plug are optional. A NEMA 15-30R receptacle is also available as an option. Canada & others require a breaker 5 AMPS greater then breaker size shown

NET WT OVEN	Shipping Weights lbs(kg)			Oven - Shipping Dimensions in(mm)		
	Oven	17" Base Base w/Legs	33" Base Base w/Legs	Length	Width	Height
609(276)	362(164)	130(59)	120(54)	69(1753)	45(1143)	34(864)

