

OWNERS MANUAL

CM-1401T

COMMERCIAL MICROWAVE OVEN

1400 watts

Bonn

COMMERCIAL MICROWAVE OVEN

Table of contents

Important Safety Instructions	1
Installing your Commercial Microwave Oven	2
Stacking Instructions	2
Control Panel.....	3
Manual Heating	3
Preprogrammed Heating.....	4
Changing Preprogrammed Button Settings.....	4
20 Sec Button	5
Changing Oven Options	5
Caring for and Cleaning your Commercial Microwave Oven	6
Air Filter Cleaning	6
Stirrer Cover Cleaning	6
Utensil Guide.....	7
Heating Tips	7
Before you call for service.....	8
Questions and Answers	8
Specifications.....	9

Thank you
for purchasing a

Bonn

Commercial Microwave Oven.

**This product has been
designed and tested to
provide years of reliable
performance.**

**Please keep this manual
for further reference.**

For any further enquiries contact:

Bonn Appliances (ACN 104 849 603)
4/40 Rivergate Place,
Murarrie Qld 4172 Australia

Phone 07-3390 4185
Int. +61-7-3390 4185
Fax 07-3393 9508
info@bonnappliances.com
www.bonnappliances.com

Important Safety Instructions

- (a) Under no circumstances should any attempt be made to operate the oven with the door open or to tamper with the safety interlocks (door latches) or to insert anything into the safety interlock holes.
- (b) Do not place any object between the oven door and front face or allow food or cleaner residues to accumulate on sealing surfaces. Ensure that the door and door sealing surfaces are kept clean by wiping after use first with a damp cloth and then with a soft dry cloth.
- (c) Do not operate the oven if it is damaged until it has been repaired by a qualified microwave service technician. It is particularly important that the oven door closes properly and that there is no damage to the:
 - (1) Door, door seals and sealing surfaces
 - (2) Door hinges (broken or loose)
 - (3) Power cable
- (d) The oven should not be adjusted or repaired by anyone other than a properly qualified microwave service technician.
- (e) **WARNING:** it is hazardous for anyone other than a competent person to carry out any service or repair operation that involves the removal of a cover which gives protection against exposure to microwave energy.
- (f) **WARNING:** only allow children to use the oven without supervision when adequate instructions have been given so that the child is able to use the oven in a safe way.
- (g) **WARNING:** liquids and other foods must not be heated in sealed containers since they are liable to explode.
- (h) **WARNING:** microwave heating of beverages can result in delayed eruptive boiling, therefore care must be taken when handling the container.
- (i) **WARNING:** the contents of feeding bottles and baby food jars must be stirred or shaken and the temperature checked before consumption in order to avoid burns.

Installing Your Commercial Microwave Oven

1. Always install the oven at bench height (90cm) on a level stable surface. Installation at chest or head height is dangerous and can result in burns to the operator and also places excessive strain on the door hinges.
2. Never block the air vents as the oven may overheat and automatically switch itself off. The oven will remain inoperable until it has cooled sufficiently. Recommended ventilation space is 10cm behind the oven and 15cm to the sides and top of the oven.
3. Remove all packing materials inside the oven including protective film from the outer cabinet of the oven.
4. For your personal safety, only plug the power lead into a 3-pin, 15amp, 240 Volt, 50Hz, AC earthed socket. If the power lead of this appliance is damaged, it must be replaced by the manufacturer or its service agent or a similarly qualified person in order to avoid any hazard.
5. This microwave oven should be positioned so that the power plug is accessible.

Outdoor use

This microwave oven is not designed for outdoor use. It should only be installed indoors.

Recommendations

- DO NOT install the microwave oven in hot or damp surroundings. Example: Next to a traditional oven, stove or dishwasher.
- The power supply specifications of the oven must be adhered to and any extension cable used must be of the same rating as the power cable supplied with the oven.
- Wipe the interior and the door seal with a damp cloth before using your microwave oven for the first time.

Stacking Instructions

- 1) Place one microwave oven on top of the other one, and remove the securing plates that are held by a single screw to the bottom-right corner at the rear of both microwaves. Secure in the above hole of the two microwaves.
- 2) Remove the two screws which are securing at both end of the cabinet of the lower microwave oven. Remove the two screws which are securing the bottom corner of the upper microwave oven.
- 3) Use the upper and lower plate screw holes to secure the upper and lower microwave ovens with the four screws.
- 4) Ensure the top oven is at a safe and workable height.

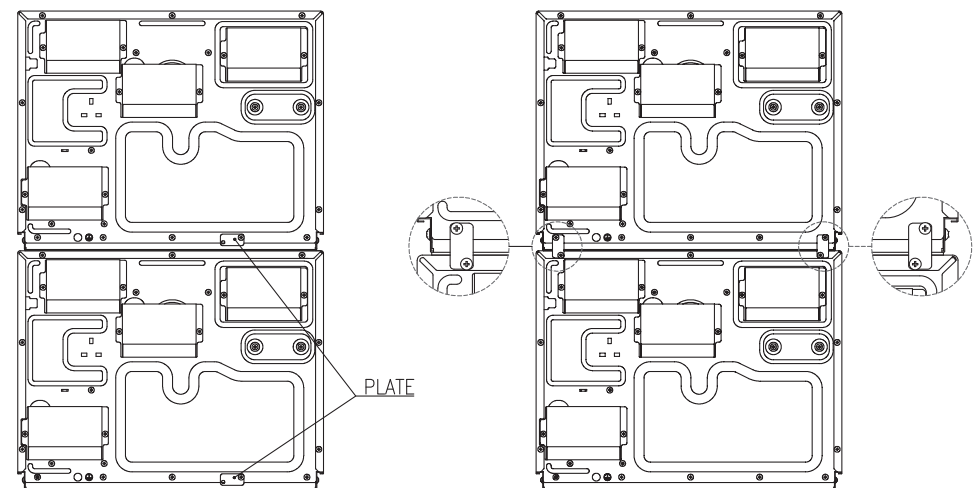

Important

The wires in this mains lead fitted to this appliance are coloured in accordance with the following code.

Green-and-yellow : Earth
Blue : Neutral
Brown : Live

As the colours of the wires in the mains lead of this appliance may not correspond with the coloured markings identifying the terminals in your plug, proceed as follows: the wire which is coloured green-and-yellow must be connected to the terminal in the plug which is marked with the letter 'E', the earth symbol or coloured green-and-yellow. The wire which is coloured blue must be connected to the terminal which is marked with the letter 'N' or coloured black.

The wire which is coloured brown must be connected to the terminal which is marked with the letter 'L' or coloured red.

WARNING: This appliance must be earthed.

Control Panel

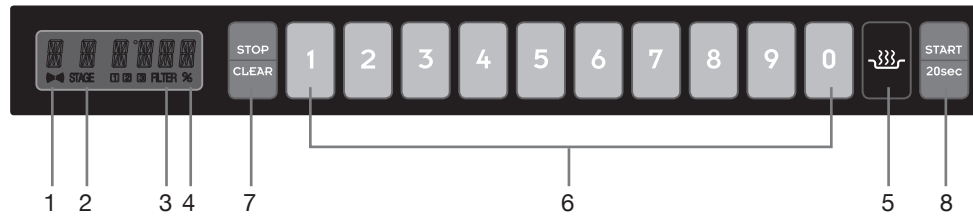

- | | |
|--|--|
| <p>1 MICROWAVE indicator
Lights when the microwave is in operation.</p> <p>2 MULTI STAGE indicator
Indicates which STAGE of multi-stage heating is in progress</p> <p>3 CLEAN FILTER indicator
Will display when the filter needs cleaning.</p> <p>4 POWER LEVEL indicator
It will turn on when button is pressed unless at full power.</p> <p>5 button
 button is used to change power level.</p> <p>6 Number buttons (1-0)
Number buttons are used to enter heating time and start preprogrammed heating cycles.</p> | <p>7 STOP button
Stops and Clears heating cycle. Also deletes changes made to programming.</p> <p>8 START/20sec button
The START button is used to start a manual heating cycle. It is also used to save any changes to programming sequences or user options. The START/20sec button can also be used as an instant heating button. In Standby mode, the 20sec button offers instant heating of 20 seconds at full power. By repeatedly pushing the 20sec button, up to 5 minutes at 20 second increments can be selected. Power level is Hi.</p> |
|--|--|

Wattage output chart

- The power level can be changed by touching the button. The chart below provides the power level choices and the percentage of power these relate to.

Power Level (Display)	Approximate Percentage of Power
HI	100%
70%	70%
50%	50%
20%	20%
00%	0%

Manual Heating

To heat food manually using a specific heating time and power level.

- Open the door and place food in the oven. Close the door.
 - “HELLO” will show in the display.
- Press button.
 - When “HI” shows in the display, the power level is full power.
 - The % indicator will light if a lower power level is selected.
 - Power levels can be adjusted by pressing button repeatedly.
- Use number buttons 1-0 to enter desired heating time.
 - Default maximum heating time is 60 minutes.
 - To reduce maximum heating time to 10 minutes, see Oven Options on page 5 in this manual.
- If Multi Stage heating is desired, repeat steps 2 and 3.
 - The display will indicate the stage being entered.
 - Up to three different stages are possible.
- Press START button.
 - The oven lamp will turn on and heating will start.
 - The STAGE indicator will start to blink and heating time will count down.



NOTE

Repeat Function: The user can repeat exactly the same heating time and power level by pressing the START button again before the oven goes into standby mode (60secs). See Oven Options on page 5 to activate this function.

NOTE

The cooling fan will continue to run for 60 seconds to cool the oven down after operation.

Preprogrammed Heating

To heat food using preprogrammed number buttons.

1. Open the door and place food in the oven. Close the door.
 - “HELLO” will show in the display.
2. Press the desired number button.
 - Press desired preset program from 1-0.
3. Oven heating cycle starts immediately.
 - The oven lamp will turn on and heating will start.
 - The STAGE indicator will start to blink and heating time will count down.

NOTE

To increase the maximum number of programmable presets from 10 to 200, see Oven Options on page 5.



Default factory settings supplied with oven

Button	Heating time	Power Level
1	10 sec.	100%
2	20 sec.	100%
3	30 sec.	100%
4	45 sec.	100%
5	1 min.	100%
6	1 min. 30 sec.	100%
7	2 min.	100%
8	3 min.	100%
9	4 min.	100%
0	5 min.	100%

NOTE

The cooling fan will continue to run for 60 seconds to cool the oven down after operation.

Changing Preprogrammed Button Settings

1. Open the door.
 - Display turns off.
2. Press and hold  button for 5 seconds.
 - When the oven enters Programming mode, “PROGRAM” will show in the display.
3. Select the number button to be programmed (1-0).
 - The display will show the program number selected. (See note below.)
4. Press  button to select desired power level.
 - If “HI” shows in the display, the power level is set to full power.
 - The % indicator will light if a lower power level is selected.
 - Power levels can be adjusted by pressing  button repeatedly.
5. Using number buttons 1-0 enter the heating time.
6. If Multi Stage heating is desired, repeat steps 4 and 5.
 - The display will indicate the stage being entered.
 - Up to three different stages can be programmed.
7. Press START to save the program changes.
 - To discard changes, press STOP button.

NOTE

To increase the maximum number of programmable presets from 10 to 200, see Oven Options on page 5.

20sec Button

This function allows for instant heating at 20 second increments at Hi power.

By repeatedly touching the 20sec button, heating time of up to 5 minutes at full power can be chosen.

1. Open the door and place food in the oven. Close the door.
 - “HELLO” will show on the display.
2. Press 20sec button.
 - Press 20sec button, “ :20” shows in the display.
 - The oven will start immediately. To increase heating time by 20 seconds press 20sec button again. Up to 5 minutes heating time can be selected.

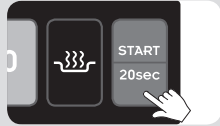

NOTE

The cooling fan will continue to run for 60 seconds to cool the oven down after operation.

Changing Oven Options

Oven Options can be changed to suit individual preferences according to the options table below.

1. Open the door.
 - Display turns off.
2. Press and hold STOP button for 5 seconds.
 - When the oven enters Oven Options mode, “CODE---” will be displayed.
3. Enter the two digit code to activate the desired option. For example, to turn off touch pad beeping, press 2 followed by 1.
4. Press START to save changes.
 - To make further changes repeat steps 3 and 4.



Oven Options

Function	Code	Description (Factory default setting in bold)
Changing Heating Completion Sound	CODE 1-0	3 long beeps for 3 seconds
	CODE 1-1	1 short, 1 long beeps for 3 seconds
	CODE 1-2	3 second beep
	CODE 1-3	3 quick beeps for 3 seconds
	CODE 1-4	5 quick beeps for 3 seconds
Turning Off Touch Pad Beep	CODE 2-0	Touch pad beeps when pressed.
	CODE 2-1	No beep when button is pressed.
Turning Off Multi Stage Notification Beep	CODE 3-0	The oven will beep when multi stage heat changes to the next stage.
	CODE 3-1	No beep when multi stage heating changes to the next stage.
Adjusting Maximum Possible Heating Time	CODE 4-0	Maximum Heating Time is 60 minutes.
	CODE 4-1	Maximum Heating Time is 10 minutes.
Changing Number Of Preprogrammed Heating Choices	CODE 5-0	10 preprogrammed settings available (0-9)
	CODE 5-1	200 preprogrammed setting available (0-199)
Adjusting Standby Activation Time	CODE 6-0	Display will turn off after 1 minute.
	CODE 6-1	Display will turn off after 2 minutes.
	CODE 6-2	Display will turn off after 3 minutes.
	CODE 6-3	Display will turn off after 4 minutes.
Repeat Function	CODE 7-0	Repeat function deactivated.
	CODE 7-1	Repeat function activated.
Activating Heating Completion Message	CODE 8-0	No END message after finishing heating cycle.
	CODE 8-1	Activation of “END” message after heating cycle.
Deactivating Manual Oven Operation	CODE 9-0	The user may use preprogrammed buttons and manual time heating.
	CODE 9-1	The user may use preprogrammed buttons only.
Clean Air Filter Reminder	CODE 0-0	Clean filter message will show up for 24 hours every 90 days.
	CODE 0-1	Clean filter message will show up for 24 hours every 60 days.
	CODE 0-2	Clean filter message will show up for 24 hours every 30 days.
	CODE 0-3	Clean filter message will show up for 24 hours every 10 days.
	CODE 0-4	The oven will not display clean filter message.

Caring for & Cleaning your Commercial Microwave Oven

1. Turn oven off before cleaning.
2. Clean oven daily. Ensure any large spills are cleaned immediately to prevent unnecessary repairs to the oven.
3. Should the oven touch pad become wet, wipe dry immediately using a soft cloth.
4. Clean oven cavity and door with a warm soft damp cloth removing food spatters and spilled liquids.
5. Clean oven door and oven casing using a soft damp cloth.
6. Use only a mild hand soap to remove stubborn grease and fat spatters.
7. Never use harsh abrasive pads or heavy chemicals, cleaning sanitisers or oven cleaners to clean the oven. These will cause damage to the oven door and stirrer cover.
8. Remove stirrer cover from oven cavity and clean daily. See page 6 for instructions.
9. Remove and clean air filter when necessary. See page 6 for instructions.

Air Filter Cleaning

The air filter must be kept clean at all times. Failure to keep it clean will result in oven overheating and possible oven repairs to the user.

1. Remove the screws at the lower left and right sides of the Air Filter.
2. Carefully remove filter.
3. Wash filter in hot soapy water to remove all blockages.
4. Wipe air intake vents clean on the oven chassis before replacing air filter.

Note The oven features an Air Filter cleaning reminder in the display. This air filter reminder is automatically activated every 90 days (The Air Filter reminder does not detect if the filter is blocked and needs cleaning). The reminder interval can be reduced to 60, 30 or 10 days in the Oven Options on page 5. The clean Air Filter reminder will automatically clear after 24hrs.

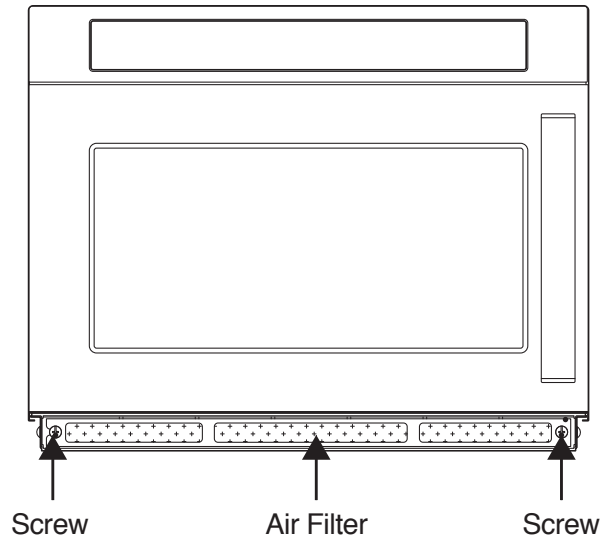

Stirrer Cover Cleaning

The stirrer cover is a critical component in the microwave oven. The stirrer cover is positioned in the ceiling of the oven cavity and prevents fat, grease, etc. from entering sensitive parts of the microwave oven. The Stirrer Cover must be cleaned on a daily basis or sooner if covered in heavy spattering of grease, fat, cheese, jam, gravy or any other similar product.

1. Position left finger at the front centre of the stirrer cover to the left of the stirrer cover fixing clip. Push finger upwards in the gap between stirrer cover edge and the stainless oven cavity.
2. Gently push the stirrer cover fixing clip to the right (3-4mm), at the same time use right finger pulling the stirrer cover downwards (5-10mm) in the centre front next to the fixing clip. This process releases the stirrer cover fixing clip.
3. Gently push up the stirrer cover clips located on the front left and right corners of the stirrer cover to release stirrer cover completely. Carefully remove stirrer cover from oven.
4. Clean stirrer cover thoroughly using warm water and mild hand soap. Do not use harsh abrasive pads or sanitisers. Do not place in dishwasher.
5. Clean oven ceiling being careful not to damage the stirrer fan.
6. Replace stirrer cover before using oven.

Note Failure to clean the stirrer cover may result in melting or even fire to the stirrer cover. This will result in unnecessary repair charges to the user. Using the oven without the stirrer cover may also result in excessive unnecessary repair charges. Please ensure stirrer cover is replaced should it become damaged or disfigured.

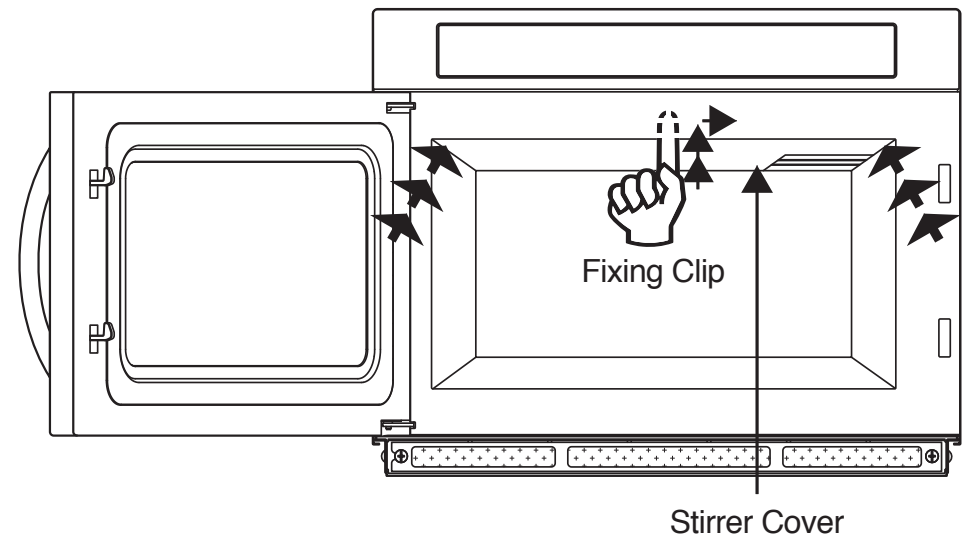

Utensil Guide

Only use utensils that are suitable for use in microwave ovens.

To heat food in the microwave oven, the microwave energy must be able to penetrate the food without being reflected or absorbed by the dish used. Care must therefore be taken to ensure that all dishes used are Microwave Safe.

The table below shows various products and their suitability.

Utensil	Comments
Aluminium foil	Can be used in small quantities to protect areas against overheating. Arcing can occur if the foil is too close to the oven wall or if too much foil is used.
Crust plate	Do not heat for more than 8 minutes.
China and earthenware	Porcelain, pottery, glazed earthenware and bone china are usually suitable, unless decorated with a metal trim. Check before use.
Disposable polyester cardboard dishes	Some frozen foods are packaged in these dishes and may not be suitable. Check before use.
Fast-food packaging • Polystyrene cups containers • Paper bags or newspaper • Recycled paper or metal trims	Can be used to warm food. Overheating may cause the polystyrene to melt. May catch fire. May cause arcing.
Glassware • Oven-to-table ware • Fine glassware • Glass jars	Can be used, unless decorated with a metal trim. Can be used to warm foods or liquids. Delicate glass may break or crack if heated suddenly. Must remove the lid. Suitable for warming only.
Metal • Dishes • Freezer bag twist ties	May cause arcing or fire. Not suitable. Not suitable.
Paper • Plates, cups, napkins and Kitchen paper • Recycled paper	For short heating times and warming. Also to absorb excess moisture. May cause arcing. Not suitable.
Plastic • Containers • Cling film • Freezer bags	Heat Resistant Thermoplastic can be used. Some other plastics may warp or discolour at high temperatures. Do not use Melamine plastic. Can be used to retain moisture. Should not touch the food. Take care when removing the film as hot steam will escape. Only if boilable or oven-proof. Should not be airtight. Prick with a fork, if necessary.
Wax or grease-proof paper	Can be used to retain moisture and prevent spattering.

Heating Tips

Moisture Content

Many fresh foods e.g. vegetables and fruit, vary in their moisture content throughout the season. For this reason heating times may have to be adjusted. Dry ingredients e.g. rice, pasta, can dry out during storage so heating times may differ.

Density

Porous airy foods heat more quickly than dense heavy foods.

Cling Film

Cling film helps keep the food moist and the trapped steam assists in speeding up heating times. Pierce before heating to allow excess steam to escape. Always take care when removing cling film from a dish as the build-up of steam will be very hot.

Shape

Even shapes heat evenly. Food heats better when in a round container rather than square.

Spacing

Foods heat more quickly and evenly if spaced apart. NEVER pile foods on top of each other.

Starting Temperature

The colder the food, the longer it takes to heat up. Food from a fridge takes longer to heat than food at room temperature.

Liquids

All liquids must be stirred before and during heating. Water especially must be stirred before and during heating, to avoid eruption. Do not heat liquids that have previously been boiled. DO NOT OVERHEAT.

Turning & Stirring

Some foods require stirring during heating. Meat and poultry should be turned after half the heating time.

Arranging

Individual foods e.g. chicken portions or chops, should be placed on a dish so that the thicker parts are towards the outside.

Quantity

Small quantities heat faster than large quantities, also small meals will heat more quickly than large portions. Heating multiple quantities at a single time will not always produce even heating. Microwave ovens are designed to heat single portions.

Piercing

The skin or membrane on some foods will cause steam to build up during heating. These foods must be pierced or a strip of skin should be peeled off before heating to allow the steam to escape.

Eggs, potatoes, apples, sausages etc, will all need to be pierced before heating. DO NOT ATTEMPT TO BOIL EGGS IN THEIR SHELLS.

Covering

Cover foods with microwave cling film or a lid. Cover fish, vegetables, casseroles, soups. Do not cover cakes, sauces, jacket potatoes or pastry items.

Before You Call For Service

Refer to following checklist, you may prevent an unnecessary service call.

The oven doesn't work

1. Check that the power cord is securely plugged in.
2. Check that the door is firmly closed.
3. Check that the heating time is set.
4. Check for a blown circuit fuse or tripped main circuit breaker in your house.
5. Have the power point you are using tested.

Sparking in the cavity

1. Check that utensils are not metal or dishes with metal trim.
2. Check that no metal is being used in the oven.
3. Clean oven thoroughly removing all fat and grease.

WARNING: DO NOT ATTEMPT TO SERVICE THE OVEN YOURSELF!

For any further enquiries contact:

Bonn Appliances (ACN 104 849 603)
4/40 Rivergate Place, Murarrie Qld 4172 Australia

Phone 07-3390 4185
Int. +61-7-3390 4185
Fax 07-3393 9508
info@bonnappliances.com
www.bonnappliances.com

Questions And Answers

Q : Can I open the door when the oven is operating?

A : The door can be opened anytime during the heating operation. The microwave energy will be instantly switched off and the time setting will maintain until the door is closed and START is touched.

Q : Why do I have moisture in my microwave oven after heating?

A : The moisture on the side walls of your microwave oven is normal. It is caused by steam while heating food.

Q : Does microwave energy pass through the viewing screen in the door?

A : No. The metal screen reflects the energy back into the oven cavity. The holes in the door are made to allow light to pass through. No microwave energy passes through.

Q : Why do eggs sometimes pop?

A : When baking or poaching eggs, the yolk may pop due to steam build-up inside the yolk membrane. To prevent this, simply pierce the yolk with a toothpick before heating. Never heat eggs without piercing their shells.

Q : Why is standing time recommended after the heating operation has been completed?

A : Standing time is very important.
With microwave heating, the heat is in the food, not in the oven. Many foods build up enough internal heat to allow the heating process to continue, even after food is removed from the oven. Standing time for joints of meat, large vegetables and cakes allows the inside to heat completely, without overheating the outside.

Q : What does "standing time" mean?

A : "Standing time" means that food should be removed from the oven and covered for additional time to allow heating to finish (usually a few minutes).

Q : Will the microwave oven be damaged if it is operated while empty?

A : Yes. Never run it empty.

Specifications

Model		CM-1401T 
Power Supply		240V Ac 50Hz Single Phase With Earthing
	Power Consumption	2200W
Microwave	Output Power	1400W
	Frequency	2450MHz
Net. Weight		APPROX. 31kg (75.1lbs)
Outside Dimensions (W X H X D)		465 X 370 X 599 mm
Cavity Dimensions (W X H X D)		371 X 199 X 372 mm
Timer		60 min.
Power Selections		5 LEVELS

* Specifications are subject to change without notice.

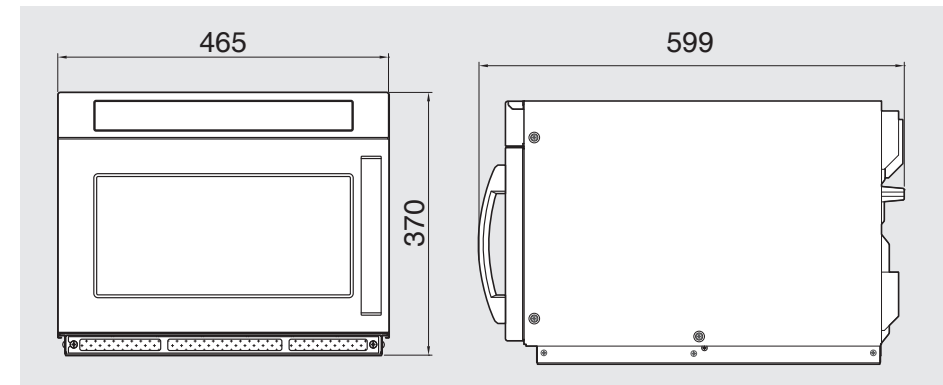

Bonn

COMMERCIAL MICROWAVE OVEN

ABOUT THIS MANUAL

VISION CREATIVE INC.

서울 종로구 통의동
6번지 이룸빌딩 4층

담 당	이수용 님		
브 랜 드	Bonn	언 어	영어
F.MODEL	KOM9F2CTTUA01KHTA3		
B.MODEL	CM-1401T		
B U Y E R			
COUNTRY	호주향 상업용		
인 쇄	중국		
MEMO	(총 12p)_pdf 받아서 작업 150629 - 총 2p(표지,9) 150630 - 총 1p(9) 150714 - 총 2p(표지,표4)_이승현 님		

연락처

VISION 담 당 방문 수(chois)
TEL : 730-0660 FAX : 730-3788