

## Large tilting braising pan with mixer direct gas heating



STEWES  
GOULASH  
SAUCES  
VEGETABLES  
ONIONS  
PASTA STUFFINGS

### EQUIPMENT FOR PROFESSIONAL KITCHENS

Safety, reliability, better quality of the finished product, greater availability of human resources, savings in time and money can be summed up in one word: CUCIMIX. It is a gas or electric tilting bratt pan with direct heating and built-in mixer, designed for large catering services and the food industry.

### THE BEST IN TILTING BRAISING PANS

This multifunctional cooker is complete, innovative and sturdy, ideal for countless applications, from sauces to jams and marmalades, from meat to steamed vegetables. Among the equipment for professional kitchens, Cucimix is really one of the most versatile and evolved, since it allows different types of preset cooking: steaming, boiling, pressure cooking, braising and browning.

Heating type	direct gas
Capacity (L)	310
Surface (dmq)	-
Gas connection (Ø)	3/4"
Electric connection (V/-/Hz)	1N+PE AC 230 V 50 Hz

Width (mm)	1755
Depth (mm)	1560
Height (mm)	1285
Gas power (Mj/hr)	176.4
Electric power (kW)	0.6

boiling | **braising** | pasteurising | **tilting** | **mixing** | cooling | frying | underpressure | vacuum cooking | cutting | washing | drying

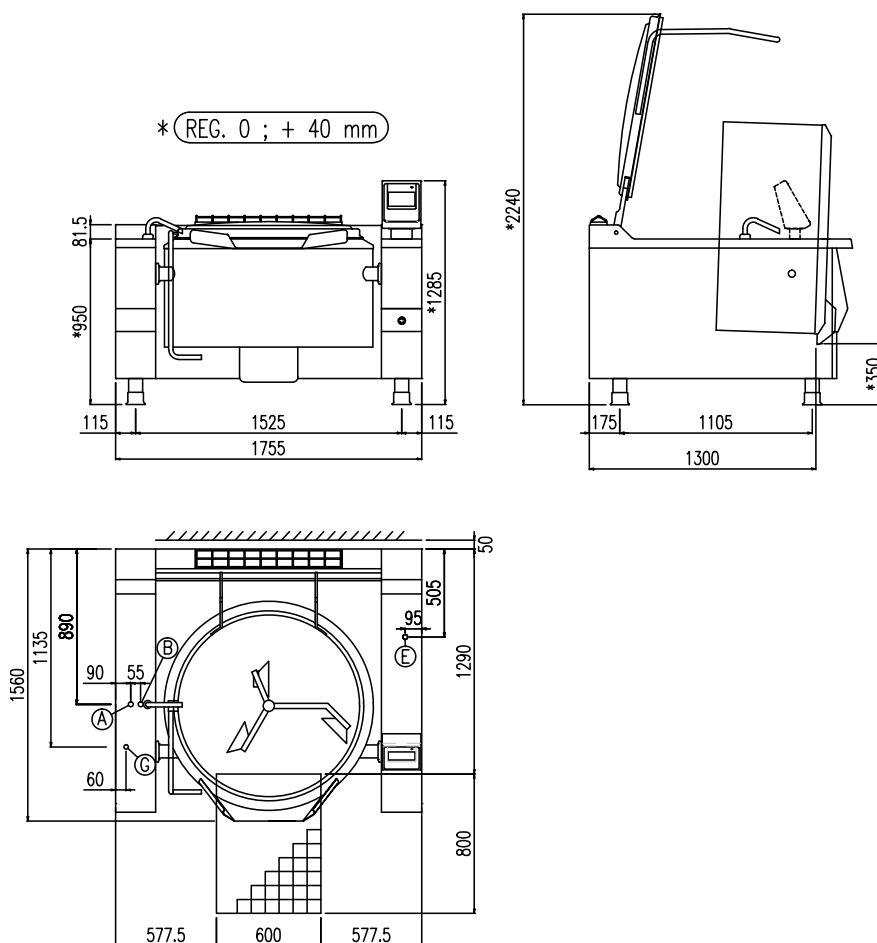

<b>G</b>	<b>Attacco Gas (secondo ISO 7-1)</b> Gas Connection (ISO 7-1)	<b>Gasanschluss (ISO 7-1)</b> Raccordement Gaz (ISO 7-1)	<b>3/4"</b>
<b>E</b>	<b>Potenza assorbita</b> Electric power	<b>Elektrische Leistung</b> Puissance Électrique	<b>.60 (kW)</b>
<b>E</b>	<b>Collegamento Elettrico</b> Electric connection	<b>Elektrische Verbindung</b> Connexion Électrique	<b>220-240V 1N ~ 50Hz</b>
<b>A</b>	<b>Allacciamento Acqua Calda</b> Hot water inlet	<b>Warmwasseranschluss</b> Raccordement eau chaude	<b>3/4"</b>
<b>B</b>	<b>Allacciamento Acqua Fredda</b> Cold water inlet	<b>Kaltwasseranschluss</b> Raccordement eau froide	<b>3/4"</b>

boiling | braising | pasteurising | tilting | mixing | cooling | frying | underpressure | vacuum cooking | cutting | washing | drying