



VERRO SERIES: VAWBT-SB2

Lower Working Height Two Burner Boiling Top

Project: _____ Item: _____



Standard Features:

- AISI 304 grade stainless steel
- Heavy duty complete stainless-steel cabinet frame
- 31MJ black enameled Italian made burner
- Removable pressed top spillage tray for easy cleaning
- Removable heavy duty 2-piece burner for easy cleaning
- Multi-setting gas valve as standard allowing for greater regulation of flame setting
- Pilot take off fitted as standard
- Heavy duty Italian made vitreous enameled trivets
- Easy access to all components for servicing and adjustment
- 24 Month warranty
- Flame Failure

Options:

- Custom Burner Configurations
- Castors
- Plinth Mounted
- Natural or LP gas

Specifications:

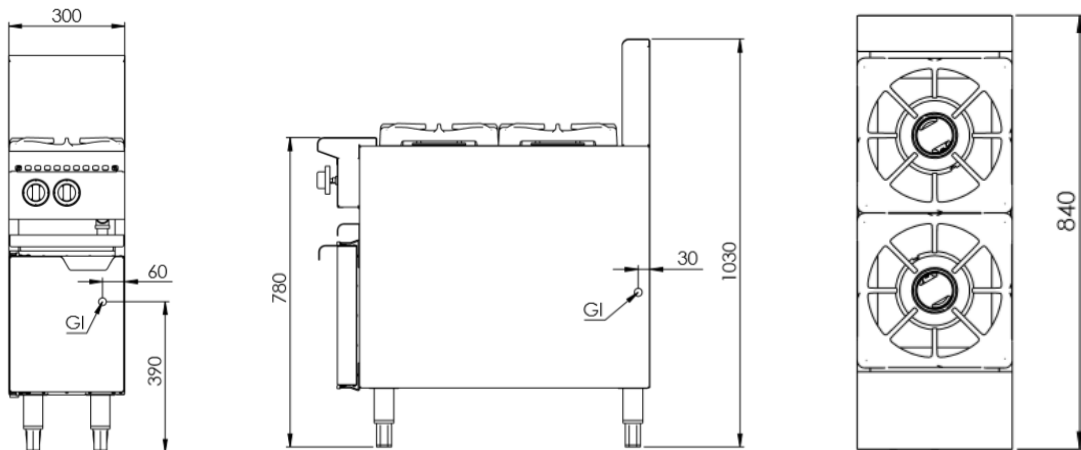

MODEL	LENGTH (mm)	DEPTH (mm)	HEIGHT (mm)	GAS CONSUMPTION (Mj/h)	
				NG	LPG
VAWBT-SB2	300	840	1030	62	50

Connections:

GAS (GI) (BSP)	SUPPLY PRESSURE (kPa)	
	NG	LPG
3/4" (M)	1.0	2.6

- Regulator is included in the unit
- **Must** be installed by an authorised installer

Due to ongoing Product Development, Product Improvement and Research, B+S Commercial Kitchens reserves the right to alter specification without notice.



B+S Commercial Kitchens
 57 Plateau Road Reservoir VIC 3073 Australia | +61 3 9469 4754
 info@bscommercialkitchens.com | www.bscommercialkitchens.com

