



# B+S BLACK SERIES: UFWWSPD-1

## Single Hole Deluxe Waterless Stock Pot

Project: \_\_\_\_\_ Item: \_\_\_\_\_



UFWWSPD-1

### Standard Features:

- AISI 304 Grade Stainless Steel
- No water deck cooling required
- Pressed top allows for easy cleaning around ring area
- Lever action gas control
- Front waste gutter allows for greater ease in cleaning
- Heavily insulated long skirt unflued cast iron rings eliminates radiant heat
- Heavy duty stainless steel frame construction throughout
- 1.5mm thick top ensuring prolonged life
- Manual operated laundry arm
- Flame failure device standard
- 18-month warranty

### Options:

- 18 jet Duck burners (DB)
- 24 jet Chimney burners (CB)
- Natural and LP Gas

### Specifications:

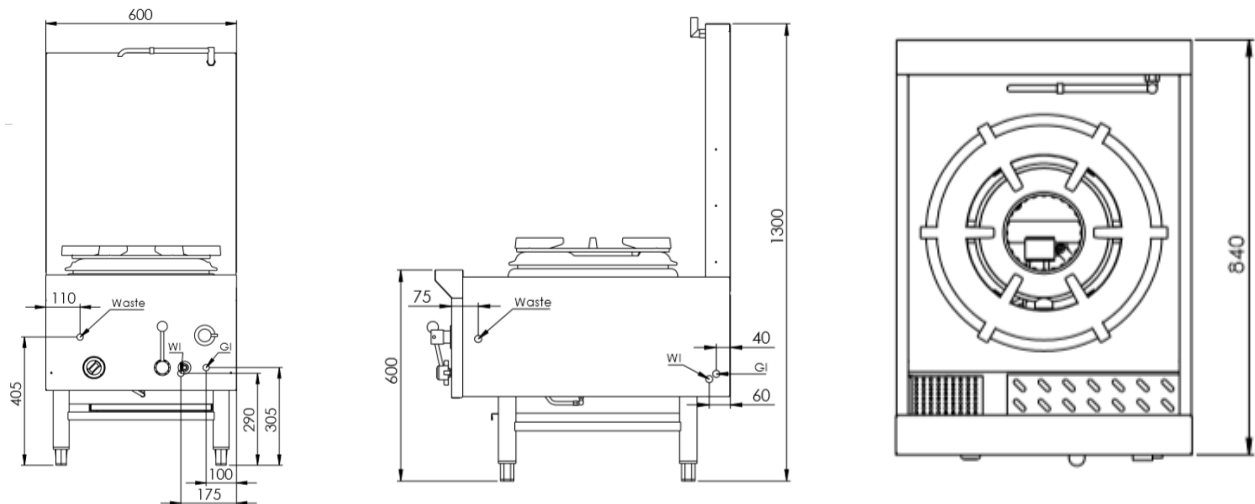

MODEL	LENGTH (mm)	DEPTH (mm)	HEIGHT (mm)	GAS CONSUMPTION (Mj/h)			
				NG - CB	NG - DB	LPG - CB	LPG - DB
UFWWSPD-1	600	840	1300	105	126	75	90

### Connections:

GAS (GI) (BSP)	WATER (WI)	WASTE (W) (BSP)	SUPPLY PRESSURE (kPa)	
			NG	LPG
¾" (M)	½" (Copper)	2" (M)	1.0	2.6

- Regulator is included in the unit
- **Must** be installed by an authorised installer

**Due to ongoing Product Development, Product Improvement and Research, B+S Commercial Kitchens reserves the right to alter specification without notice.**



B+S Commercial Kitchens  
 57 Plateau Road Reservoir VIC 3073 Australia | +61 3 9469 4754  
 info@bscommercialkitchens.com | www.bscommercialkitchens.com

