



K+ SERIES: UFWWK-2 Two Hole Waterless Wok Table

Project: _____ Item: _____



UFWWK-2

Standard Features:

- Stainless Steel External Frame
- Constructed from Heavy Duty Mild Steel Internal Frame
- 1.5mm Thick Top Deck
- Long Skirt Cast Iron Unflued Ring (340mm Diameter)
- Heavy Duty Lever Action Gas Control
- Flame Failure Device standard
- Manual Operated Laundry Arm
- 12-month warranty

Options:

- 18 jet Duck Burners (DB)
- 24 jet Chimney Burners (CB)
- Natural or LP Gas

Specifications:

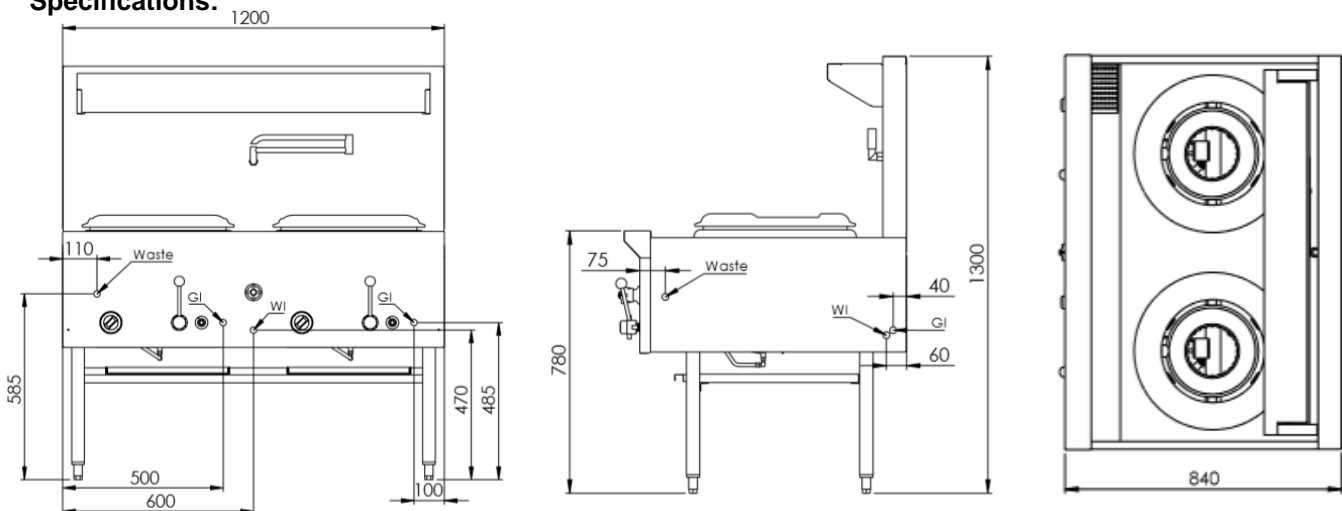

MODEL	LENGTH (mm)	DEPTH (mm)	HEIGHT (mm)	GAS CONSUMPTION (Mj/h)			
				NG - CB	NG - DB	LPG - CB	LPG - DB
UFWWK-2	1200	840	1300	210	220	150	180

Connections:

GAS (GI) (BSP)	WATER (WI)	WASTE (W) (BSP)	SUPPLY PRESSURE (kPa)	
			NG	LPG
3/4" (M)	1/2" (Copper)	2" (M)	1.0	2.6

- Regulator is included in the unit
- Unit must be connected by **two** gas lines
- **Must** be installed by an authorised installer

Due to ongoing Product Development, Product Improvement and Research, B+S Commercial Kitchens reserves the right to alter specification without notice.



B+S Commercial Kitchens
57 Plateau Road Reservoir VIC 3073 Australia | +61 3 9469 4754
info@bscommercialkitchens.com | www.bscommercialkitchens.com

