



B+S BLACK SERIES: TF-601

Single Pan Turbo Fryer 3 Baskets

Project: _____ Item: _____



TF-601

Standard Features:

- AISI 304 grade stainless steel
- Oil temperature thermostatically regulated
- Stainless steel constructed pan with center cool zone
- Over-temperature safety cut-out switch
- 27-liter oil capacity
- Ceramic lined infra-red burner
- 2mm thick stainless-steel pan
- Efficient ceramic lined infrared burner
- Constructed on a solid stainless-steel frame
- 18-month warranty

Options:

- Natural Gas

Specifications:

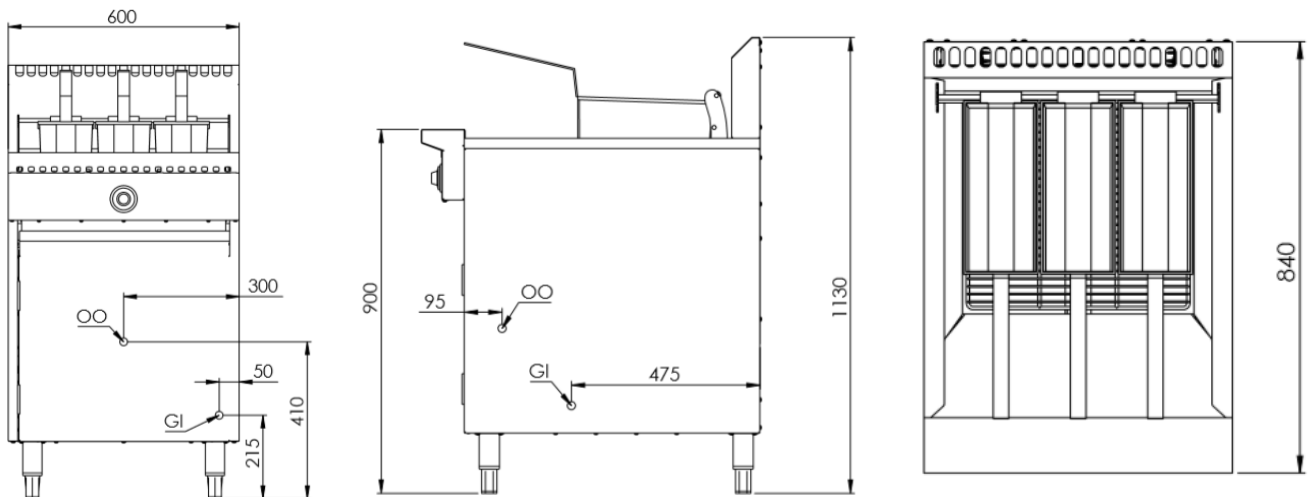

MODEL	LENGTH (mm)	DEPTH (mm)	HEIGHT (mm)	GAS CONSUMPTION (Mj/h)	
				NG	LPG
TF-601	600	840	1130	92	N/A

Connections:

GAS (GI) (BSP)	WASTE (W) (BSP) (OO)	SUPPLY PRESSURE (kPa)	
		NG	LPG
¾" (M)	1 ¼" (M)	1.0	2.6

- Regulator is included in the unit
- **Must** be installed by an authorised installer

Due to ongoing Product Development, Product Improvement and Research, B+S Commercial Kitchens reserves the right to alter specification without notice.



B+S Commercial Kitchens
 57 Plateau Road Reservoir VIC 3073 Australia | +61 3 9469 4754
 info@bscommercialkitchens.com | www.bscommercialkitchens.com

