



K+ SERIES: DR-800 Duck Oven

Project: _____ Item: _____



Standard Features:

- Stainless Steel Frame Construction Throughout
- Flame Failure as standard
- Lever action Gas Control
- Volcanic rocks included to help distribute heat evenly
- Oil drain and Overflow Valves
- Excess Fat Drain off provided by duck hanging rail
- Easily accessible duck hanging rail
- Overheat safety device
- Double skin increases cooking efficiency
- Temperature display
- 12-month warranty

Options:

- Natural or LP Gas

Specifications:

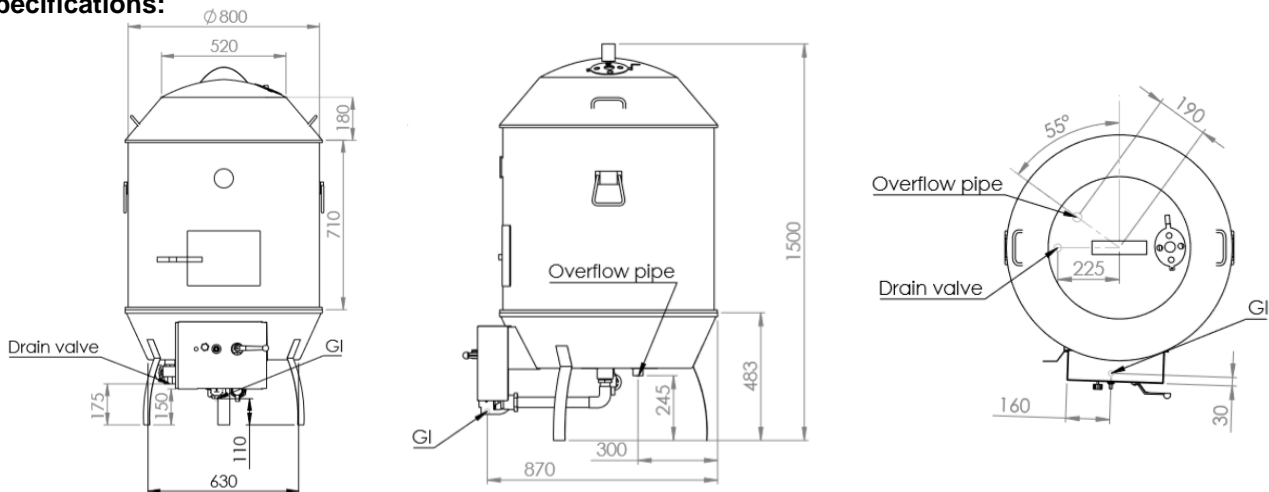

MODEL	DIAMETER (mm)	HEIGHT (mm)	GAS CONSUMPTION (Mj/h)	
			NG	LPG
DR-800	800	1500	73	60

Connections:

GAS (GI) (BSP)	Drain (W) (BSP)	OVERFLOW	SUPPLY PRESSURE (kPa)	
			NG	LPG
3/4" (M)	1" (F)	1.5" Diameter Pipe	1.0	2.6

- Regulator is included in the unit
- **Must** be installed by an authorised installer

Due to ongoing Product Development, Product Improvement and Research, B+S Commercial Kitchens reserves the right to alter specification without notice.



B+S Commercial Kitchens
57 Plateau Road Reservoir VIC 3073 Australia | +61 3 9469 4754
info@bscommercialkitchens.com | www.bscommercialkitchens.com

