

SERIE 900

Code CR0786869

Model 9CP/E400



1 BASIN ELECTRIC PASTA-COOKER 40 LT

General Characteristics

The 900 Baron line is made in compliance with strict European Standards in terms of safety, hygiene, reliability and respect for the environmental and is certified under international standards such as CE, GOST, AGA and others. Stainless steel with scotch-brite finish heightens the aesthetic appeal, and the technological and ergonomic innovation of this equipment. Thanks to great compositional flexibility, cook tops can be matched with oven bases and accessorised with hygienic finishes. Customised line-ups are possible by combining and fixing the equipment back to back, flushed sideways with perfectly sealed connections, or by creating "bridge" structures, offering top solutions to any chef. Basic range features:

- 2 mm thick moulded tops;
- 2" height adjustable stainless steel feet;
- removable control panel for access, moulded and shaped to avoid withholding dirt;
- recessed, tilted and ergonomic knobs.



PASTA COOKERS

Pasta cookers are remarkably versatile. Suitable for boiling water, rice, potato dumplings, filled pasta, vegetables and tubers in the best working conditions and with minimal manual effort.

Technical/Functional Characteristics

- Large capacity (42 litres) alloy AISI 316 stainless steel cooking tank with excellent corrosion resistance even at high temperatures. They are moulded with internal rounded corners for maximum hygiene and cleaning, and are equipped with wide foam expansion areas and a drain device for residue starch;
- Safety thermostat in tub to avoid dry functioning;
- Stainless steel armoured heating elements in tub;
- Re-arm circuit breaker of heating elements unit;
- Multi-position power regulator, independent for each tub

Technical Data

DIMENSIONS	
Width (mm)	400
Depth (mm)	900
Height (mm)	870
Gas connection (Ø)	
Electric connection (V~/HZ)	400V/3N
Cold water connection (Ø)	1/2"
Hot water connection (Ø)	

Cold soft water connection (Ø)	
Drain (Ø)	1"
Gas power (mm)	
Electric power (mm)	9
Plate dimensions (mm)	
Tank capacity (Lt)	40
TANK DIMENSIONS	(307 x 509 x 272)
Internal ovens dimension(mm)	



SERIE 900

Code CR0786869

Model 9CP/E400



Installation Layout

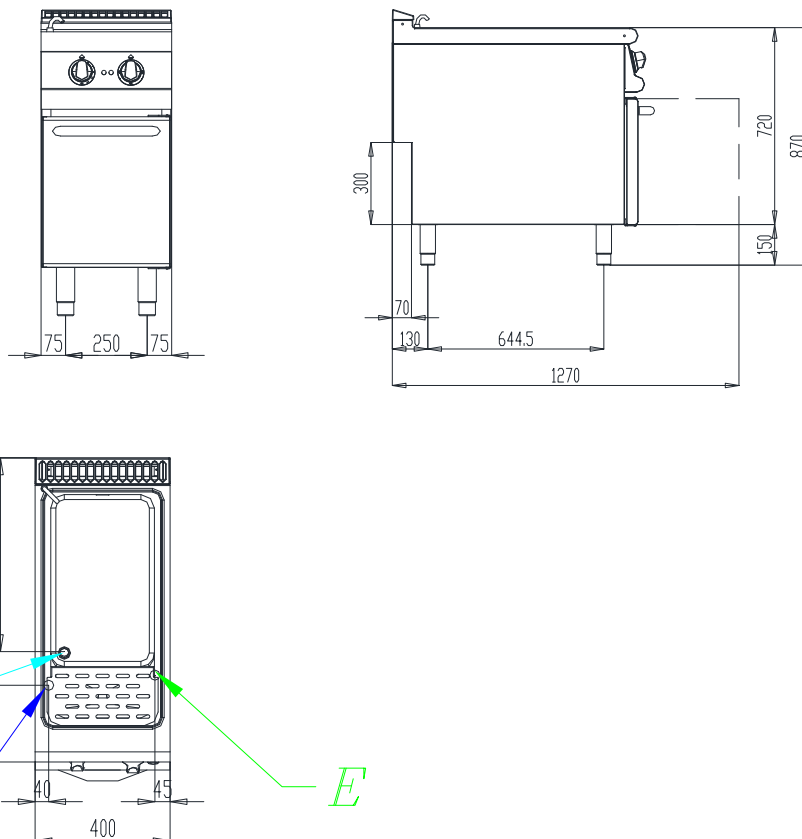

G gas connection | E electric connection | CW cold water connection | HW hot water connection | SW soft cold water connection | D drain

Accessories

Code	Description
803199010	S/S BASKET GN 1/1 FOR PASTA COOKERS
8031199020	S/S BASKET GN 1/2 FOR PASTA COOKERS
8031990130	S/S BASKET GN 1/3 FOR PASTA COOKERS
8031990140	S/S BASKET GN 1/3 FOR PASTA COOKERS
8031990150	S/S BASKET GN 1/6 FOR PASTA COOKERS - RIGHT
8031990160	S/S BASKET GN 1/6 FOR PASTA COOKERS - LEFT
8031990210	LID FOR PASTA COOKERS TANK
8031990100	BOTTOM GRID FOR PASTA COOKERS TANK
8031920400	SWIVELLING CASTOR
8031920410	SWIVELLING CASTOR WITH BRAKE
8031920600	KIT 4 SWIVELLING CASTOR (2 WITH BRAKE)
8031920610	KIT 6 SWIVELLING CASTOR (3 WITH BRAKE)
8031900340	RIGHT SIDE FINISHING END PIECE FOR 900 LINE
8031900350	LEFT SIDE FINISHING END PIECE FOR 900 LINE
8031900211	SIDE SUPPORTING TIP TOP - RIGHT - 900 SERIE
8031900460	FIXED SIDE TOP - RIGHT - 900 SERIE
8031900221	SIDE SUPPORTING TIP TOP - LEFT - 900 SERIE
8031900470	FIXED SIDE TOP - LEFT - 900 SERIE
8031920320	FRONTAL KICK PLATE W=400
8031920380	SIDE KICK PLATE 900 SERIE
0592390	CLOSING PANEL FOR 900 SERIE

