

SERIE 900

Code CR0785549

Model 90TPF/G800



GAS TARGET TOP ON GAS OVEN

General Characteristics

The 900 Baron line is made in compliance with strict European Standards in terms of safety, hygiene, reliability and respect for the environmental and is certified under international standards such as CE, GOST, AGA and others. Stainless steel with scotch-brite finish heightens the aesthetic appeal, and the technological and ergonomic innovation of this equipment. Thanks to great compositional flexibility, cook tops can be matched with oven bases and accessorised with hygienic finishes. Customised line-ups are possible by combining and fixing the equipment back to back, flushed sideways with perfectly sealed connections, or by creating "bridge" structures, offering top solutions to any chef. Basic range features:

- 2 mm thick moulded tops;
- 2" height adjustable stainless steel feet;
- removable control panel for access, moulded and shaped to avoid withholding dirt;
- recessed, tilted and ergonomic knobs.



TARGET TOPS

With its high performing central burner, the gas solid top has different heating zones, with a heat concentration that decreases towards the peripheral area, allowing for slower cooking or to keep food warm. It is available in full or half modules and is combined with gas burners or completely electric.

Technical/Functional Characteristics

- Cast iron brushed griddle with removable central disc;
- High power (14 kW) central burner with piezoelectric ignition;
- Distinguished heating zones with maximum temperature in the centre 500°C, decreasing towards the perimeter;
- safety valve with thermocouple and supplied power progressive adjustment;

Gas oven

- Stainless steel cooking area (53x70x30cm), thermally insulated and equipped with 3 antitipping guides for 2/1 Gastronorm containers;
- Very thick cast iron radiant hearth for efficient heat distribution;
- Perfectly insulated stainless steel door and inner door, fitted on self-balanced hinges;
- Full length thermally insulated ergonomic handle;
- Stabilised flame burner housed below the base plate;
- Pilot burner with piezo-electric and manual ignition;
- Automatic valve with gas safety thermocouple;
- Thermostatic temperature control from 110 to 330°C;

Technical Data

DIMENSIONS	
Width (mm)	800
Depth (mm)	900
Height (mm)	870
Gas connection (Ø)	1/2"
Electric connection (V~/HZ)	
Cold water connection (Ø)	
Hot water connection (Ø)	

Cold soft water connection (Ø)	
Drain (Ø)	
Gas power (mm)	22,5
Electric power (mm)	
Plate dimensions (mm)	791 x 700
Tank capacity (Lt)	
TANK DIMENSIONS	
Internal ovens dimension(mm)	530 x 700 x 300



SERIE 900

Code CR0785549

Model 90TPF/G800



Installation Layout

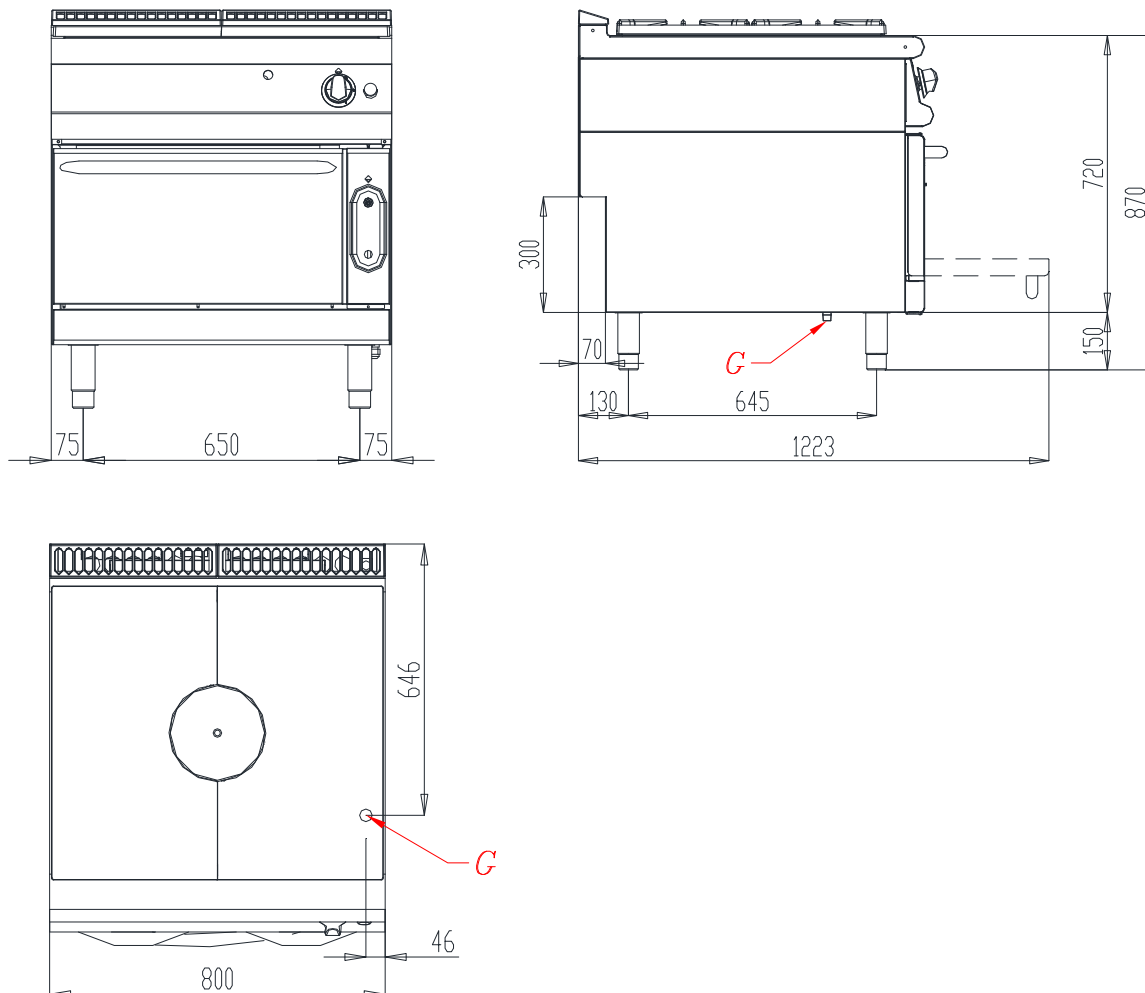

G gas connection | E electric connection | CW cold water connection | HW hot water connection | SW soft cold water connection | D drain

Accessories

Code	Description
9GF	CHROMED-WIRED GRID FOR 900 SERIE OVEN
GNB2/1-40	S/S TRAY GN2/1 H40 MM FOR 900 SERIE OVEN
GNB2/1-65	S/S TRAY GN2/1 H65 MM FOR 900 SERIE OVEN
8031920400	SWIVELLING CASTOR
8031920410	SWIVELLING CASTOR WITH BRAKE
8031920600	KIT 4 SWIVELLING CASTOR (2 WITH BRAKE)
8031900340	RIGHT SIDE FINISHING END PIECE FOR 900 LINE
8031900350	LEFT SIDE FINISHING END PIECE FOR 900 LINE
8031900211	SIDE SUPPORTING TIP TOP - RIGHT - 900 SERIE
8031900460	FIXED SIDE TOP - RIGHT - 900 SERIE
8031900221	SIDE SUPPORTING TIP TOP - LEFT - 900 SERIE
8031900470	FIXED SIDE TOP - LEFT - 900 SERIE
8031920330	FRONTAL KICK PLATE W=800
8031920380	SIDE KICK PLATE 900 SERIE
0592390	CLOSING PANEL FOR 900 SERIE

