

# SERIE 900

**Code** CR0785229

**Model** 90PCF/E801



## 4 SQUARE HOTPLATE ELECTRIC RANGE ON ELECTRIC OVEN

### General Characteristics

The 900 Baron line is made in compliance with strict European Standards in terms of safety, hygiene, reliability and respect for the environmental and is certified under international standards such as CE, GOST, AGA and others. Stainless steel with scotch-brite finish heightens the aesthetic appeal, and the technological and ergonomic innovation of this equipment. Thanks to great compositional flexibility, cook tops can be matched with oven bases and accessorised with hygienic finishes. Customised line-ups are possible by combining and fixing the equipment back to back, flushed sideways with perfectly sealed connections, or by creating "bridge" structures, offering top solutions to any chef. Basic range features:

- 2 mm thick moulded tops;
- 2" height adjustable stainless steel feet;
- removable control panel for access, moulded and shaped to avoid withholding dirt;
- recessed, tilted and ergonomic knobs.



### ELECTRIC RANGE

Excellent cooking ranges are essential in every kitchen and are extremely versatile for any type of cooking. The electric ranges are available with independent cast iron plates, glass-ceramic top or induction top.

### Technical/Functional Characteristics

- Fully moulded hob, obtained from a single large stainless steel plate;
- Water tight cast iron radiant plates to avoid liquids penetrating on electric wiring;
- Automatic safety thermostat to avoid plates overheating, particularly during empty functioning;
- Ergonomic, recessed and tilted knobs with 7 control positions ;
- Powered plates" indicator lights;

Electric oven

- Independently adjustable stainless steel heating element units positioned at the top and below the cooking area base plate;
- Thermostatic control of range temperature from 100°C to 300°C;
- Powered appliance" indicator light;
- Set temperature reached" indicating light

### Technical Data

DIMENSIONS	
Width (mm)	800
Depth (mm)	900
Height (mm)	870
Gas connection (Ø)	
Electric connection (V/~ /HZ)	400V/3N
Cold water connection (Ø)	
Hot water connection (Ø)	

Cold soft water connection (Ø)	
Drain (Ø)	
Gas power (mm)	
Electric power (mm)	22
Plate dimensions (mm)	
Tank capacity (Lt)	
TANK DIMENSIONS	
Internal ovens dimension(mm)	530 x 700 x 300



# SERIE 900

Code CR0785229

Model 90PCF/E801



## Installation Layout

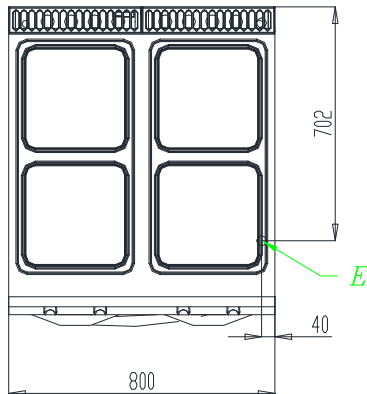
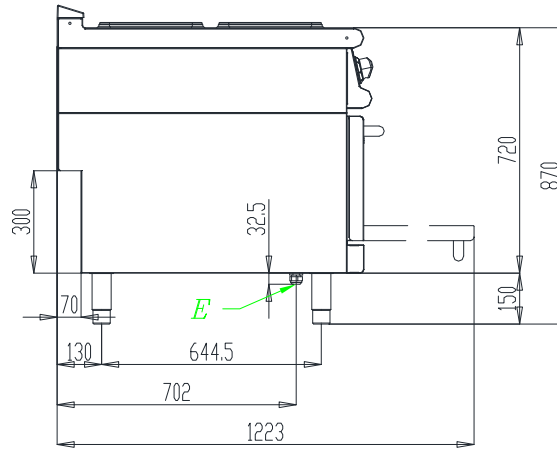
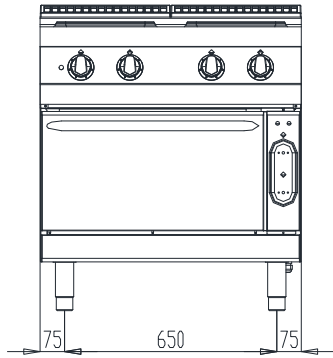

G gas connection | E electric connection | CW cold water connection | HW hot water connection | SW soft cold water connection | D drain

## Accessories

Code	Description
9GF	CHROMED-WIRED GRID FOR 900 SERIE OVEN
GNB2/1-40	S/S TRAY GN2/1 H40 MM FOR 900 SERIE OVEN
GNB2/1-65	S/S TRAY GN2/1 H65 MM FOR 900 SERIE OVEN
8031920400	SWIVELLING CASTOR
8031920410	SWIVELLING CASTOR WITH BRAKE
8031920600	KIT 4 SWIVELLING CASTOR (2 WITH BRAKE)
8031900340	RIGHT SIDE FINISHING END PIECE FOR 900 LINE
8031900350	LEFT SIDE FINISHING END PIECE FOR 900 LINE
8031900211	SIDE SUPPORTING TIP TOP - RIGHT - 900 SERIE
8031900460	FIXED SIDE TOP - RIGHT - 900 SERIE
8031900221	SIDE SUPPORTING TIP TOP - LEFT - 900 SERIE
8031900470	FIXED SIDE TOP - LEFT - 900 SERIE
8031920330	FRONTAL KICK PLATE W=800
8031920380	SIDE KICK PLATE 900 SERIE
0592390	CLOSING PANEL FOR 900 SERIE

