

VITO XS

Spec sheet



VITO X - the world's most innovative vacuum filtration system!

VITO X is best suited for catering industry, bakeries or high frying output

Functionality:

VITO X cleans the oil and stores in its 40 l (73.04 lbs) tank. It provides an easy and hygienic transport in the kitchen. Because of its innovative vacuum-filtration technology, particles remain in the filter medium in a dry condition. Like every VITO oil filter system the X provides a microfiltration up to 5 µm (0,2 µin). The optimal quality of your oil is preserved. The unique design makes sure the X can handle temperatures up to 200°C (392°F) and provides highest safety at work, due to avoiding direct contact with hot oil. After filtration the oil can easily be pumped back into the fryer automatically.

The VITO X saves oil, labour, stock ground and transport costs.

Big savings:

- less oil consumption
- less personnel costs
- less transport costs
- less storage costs
- fast amortization

Constant quality...

- ... of your frying medium
- ... of your fried dishes

Easy handling:

- automatic filtration
- fast vacuum filtration
- low cleaning effort

To optimize the benefit of the VITO X combine it with our frying oil testers: VITO oiltester or the FT440.

VITO oiltester example:



FT 440 example:



VITO - seen in 150 countries - used in over 40.000 kitchens



VITO AG

T: +49 7461 96289-0
F: +49 7461 96289 -12

info@vito.ag
www.vito.ag

VITO XS

Spec sheet

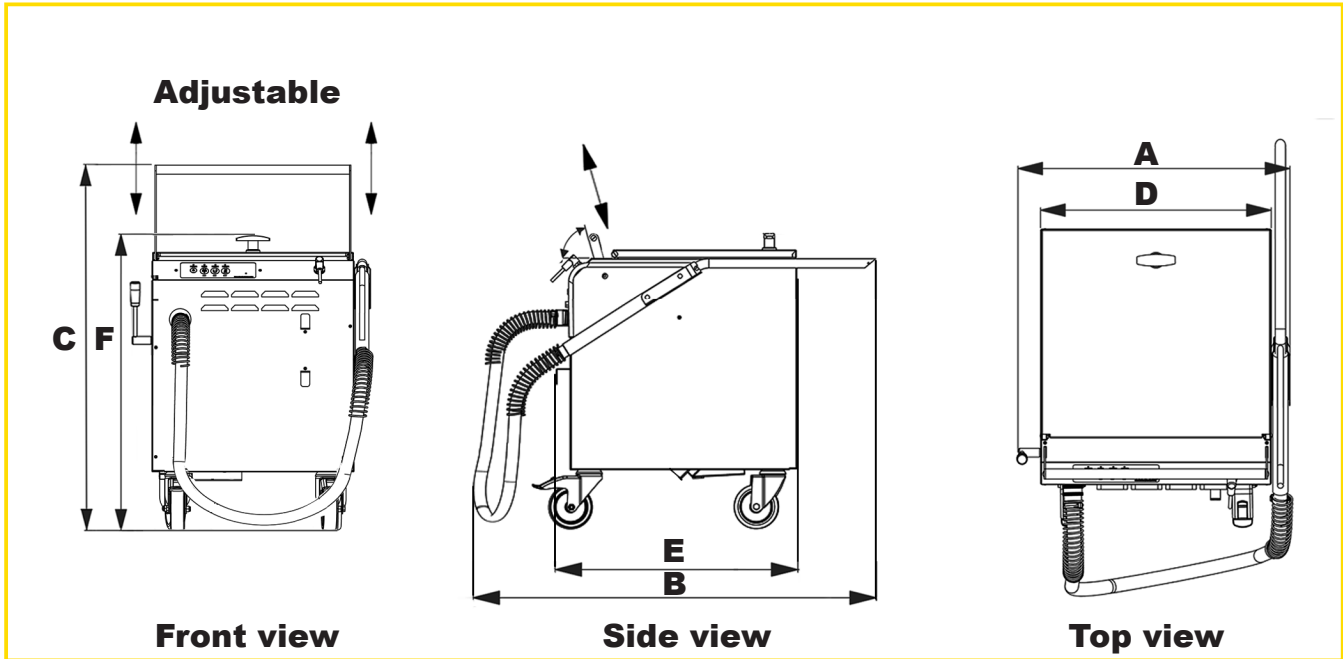

VITO X technical data:

	Width A	Depth B	Height C		Width D	Depth E	Height F	
Assembled	553 mm 21.8 in	883 mm 34.8 in	843 mm 33.19 in	Compact	469 mm 18.5 in	551 mm 21.7 in	679.5 mm 26.75 in	
Filtration power	Filtration efficiency	Particle uptake	Pumping capacity	Tank	Weight	Temperature	Material VITO	Particle filter
up to 30l/min 66lbs/min	up to 5µm 0.2µinch	10,7 kg 23.54 lbs	35l/min 77 lbs/min	40l 73.04 lbs	45kg 99 lbs	max. 200°C max. 392°F	Stainless steel 1.4301	Cellulose FDA-CFR 21

Additional features:

- ◆ The VITO X can operate in deep fryers at service temperature
- ◆ Adjustable top handle
- ◆ Automatic off - Tank with built-in oillevel sensor
- ◆ Casing made of stainless steel 1.4016, filtration basket and tank are made of stainless steel 1.4301, filter made of cellulose (All used components are food safe)
- ◆ Integrated heating for solid frying medium
- ◆ Big wheels with breaks
- ◆ Filter basket is dishwasher safe
- ◆ Easy off hose

VITO - seen in 150 countries - used in over 40.000 kitchens



VITO AG

T: +49 7461 96289-0
F: +49 7461 96289 -12

info@vito.ag
www.vito.ag