

TUC-72-HC

 Undercounter Foodservice Refrigerator, 3 Solid Swing Doors

Dimensions		Build		Technical	
External Width (mm)	1839	Door Description	3 Solid Swing Doors	Temperature Holding	0.5 : 3.3°C
External Depth (mm)	766	Exterior Construction	Stainless steel front & countertop, aluminium sides & rear	Refrigerant	R290
External Height (mm)	839	Interior Construction	Clear coated aluminium, stainless steel base	Voltage / Frequency / Phase	220-240V/50-60Hz/1
Exclusions	Depth does not include 26 mm for rear bumpers.	Air Intake Position	Front	Amps	1.4
Net Volume (Litres)	461	Ventilation Position	Front	Wattage	322
Gross Volume (Litres)	583	Clearance Required	Zero back and sides	Climate Class	5
Supplied Shelves	6	Cord Length (Meters)	2.13	Operating Statement	Heavy Duty: This appliance is intended for use in ambient temperatures up to 40°C.
Shelf Size (L x D mm)	Left & Right Upper: 547 x 514. Central Upper: 596 x 539. Left & Right Lower: 547 x 349. Central Lower: 596 x 349	Standard w/ Locks	Standard	Testing Standard	EN 16825
Internal Net Height (mm)	630			EEC	B
Unpackaged Weight (kg)	162			EEL	33.2
Packaged Weight (kg)	173			kWh/24hr	2.7
Packaged Dimensions (W x D x H mm)	1931 x 832 x 1207			kWh/Annum	985
Supplied Supports	ø 64 mm castors (83 mm height) (reduced height option available, totals 810 mm)			Defrost Type	Auto



Specifications subject to change without notice.
 Technical data above related to energy use based on testing of 50Hz or Dual Frequency models
 Chart dimensions rounded up to the next whole millimeter (inches rounded up to the 1/8")

UK & Ireland [0800 783 2049](tel:08007832049)
 EMEA [+41 61 563 07 05](tel:+41615630705)
 Australia [+61 2 9619 9999](tel:+61296199999)

TFIUK@truemfg.com
TrueCHCustomerService@truemfg.com
TrueRefAus@truemfg.com



TUC-72-HC

Undercounter Foodservice Refrigerator, 3 Solid Swing Doors

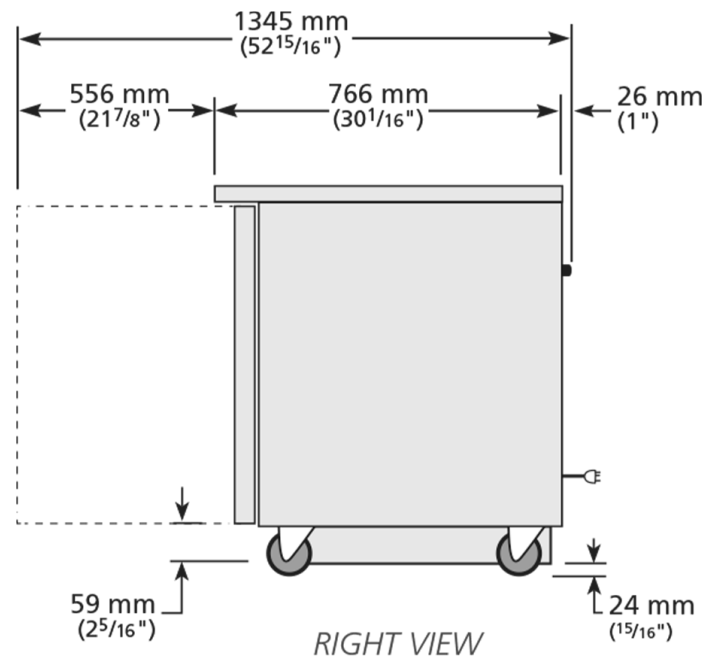
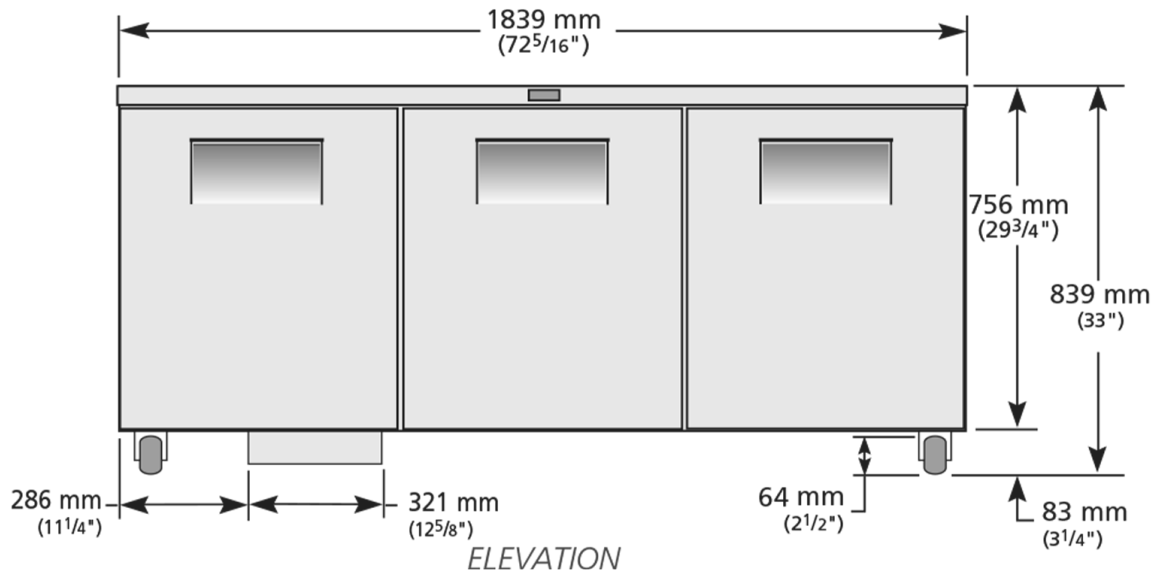

Specifications subject to change without notice.
Technical data above related to energy use based on testing of 50Hz or Dual Frequency models
Chart dimensions rounded up to the next whole millimeter (inches rounded up to the 1/8")

UK & Ireland 0800 783 2049
EMEA +41 61 563 07 05
Australia +61 2 9619 9999

TFIUK@truemfg.com
TrueCHCustomerService@truemfg.com
TrueRefAus@truemfg.com

