

Bar Refrigeration

TBR60-PTSZ1-L-B-GG-GG-2

 "Pass-Thru" Bar Refrigerator, Black Ext, 2 Glass Swing Doors Front, 2 Glass Swing Doors Rear



Dimensions		Build		Technical	
External Width (mm)	1524	Door Description	2 Full Glass Swing Doors	Temperature Holding	0.5 : 3.3°C
External Depth (mm)	631	Exterior Construction	Black powder coated steel front. Matching black coated Aluminium sides & rear. Stainless steel countertop.	Refrigerant	R290
External Height (mm)	881	Interior Construction	Stainless Steel	Voltage / Frequency / Phase	220-240V/50-60Hz/1
Exclusions	Depth does not include 35 mm for front + 35 mm for back door handles. Height does not include 7 mm for leg levelers.	Air Intake Position	Front	Amps	1.3
Gross Volume (Litres)	550	Ventilation Position	Front	Wattage	299
Supplied Shelves	6	Clearance Required	Zero back and sides	Defrost Type	Auto
Shelf Size (L x D mm)	551 x 458	Cord Length (Meters)	3.04		
Internal Net Height (mm)	730	Internal Lighting	LED		
Unpackaged Weight (kg)	174	Standard w/ Locks	standard		
Packaged Weight (kg)	185				
Packaged Dimensions (W x D x H mm)	1690 x 801 x 1067				
Supplied Supports	Leg Levelers (Castors supplied separate)				



Specifications subject to change without notice. Technical data above related to energy use based on testing of 50Hz or Dual Frequency models Chart dimensions rounded up to the next whole millimeter (inches rounded up to the 1/8")

UK & Ireland [0800 783 2049](tel:08007832049)
 EMEA [+41 61 563 07 05](tel:+41615630705)
 Australia [+61 2 9619 9999](tel:+61296199999)

TFIUK@truemfg.com
TrueCHCustomerService@truemfg.com
TrueRefAus@truemfg.com



TBR60-PTSZ1-L-B-GG-GG-2

"Pass-Thru" Bar Refrigerator, Black Ext, 2 Glass Swing Doors Front, 2 Glass Swing Doors Rear

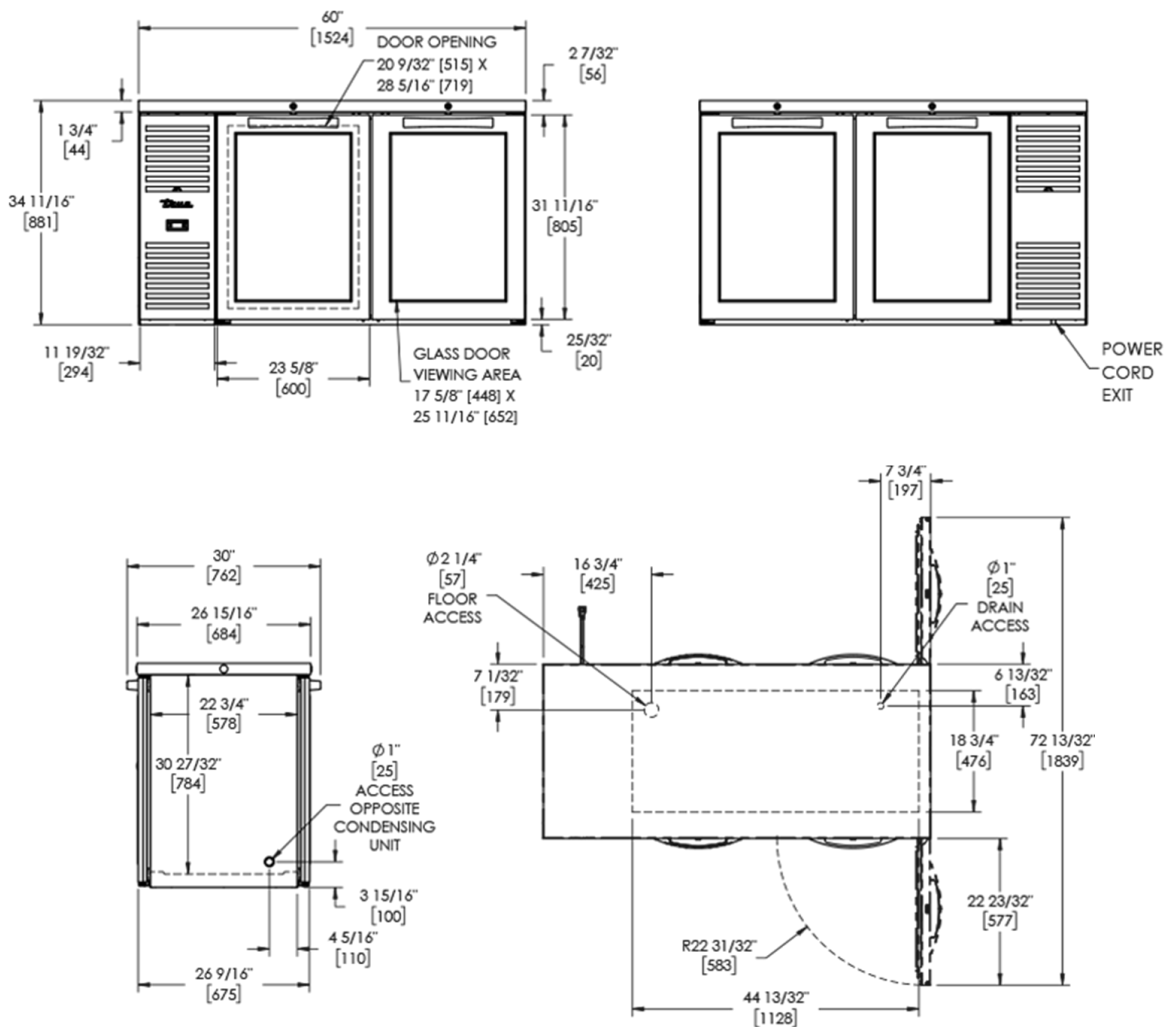

Specifications subject to change without notice. Technical data above related to energy use based on testing of 50Hz or Dual Frequency models Chart dimensions rounded up to the next whole millimeter (inches rounded up to the 1/8")

UK & Ireland 0800 783 2049
 EMEA +41 61 563 07 05
 Australia +61 2 9619 9999

TFIUK@truemfg.com
 TrueCHCustomerService@truemfg.com
 TrueRefAus@truemfg.com

