

MODEL

Q90PF/G150

CODE

CR1018029

GAS BOILING PAN - DIRECT HEATING 150 LT

QUEEN9

- AISI 304 stainless-steel bases and worktops, Scotch-Brite finish
- Depth of 900 mm for high power and performance
- Catalogue offers more than 350 standard models
- Worktop, base cabinet, base cabinet with doors and oven versions
- 20/10 worktop thickness
- Twin-piece knobs prevent infiltration of dirt and have an IPX5 water ingress protection rating
- Gas kitchens having burners with various configurations and power ratings: 3.5 kW - 5.7 kW, 7 kW and 10 kW
- Double-ring burners for 7 and 10 kW models
- Wide range of accessories



Technical / functional characteristics

- Water drained with 2" valve
- AISI 316 stainless steel container bottom
- No water in the interspace indicator light;
- Safety thermostat to interrupt heating until restore of sufficient water level;
- 2 AISI 304 steel burners on bottom of container or interspace

DIMENSIONS	
Width (mm)	800
Depth (mm)	900
Height (mm)	900
Gas connection (∅)	1/2"
Electric connection (V/~ /Hz)	230V/1N 50 Hz
Cold water connection (∅)	3/4"
Hot water connection (∅)	3/4"

Cold soft water connection (∅)	
Drain (∅)	1 1/2"
Gas power (Mj/hr)	76
Electric power (kW)	0.2
Plate dimensions (mm)	
Tank capacity (L)	150
Tank dimensions (mm)	
Internal oven dimensions (mm)	

MODEL

Q90PF/G150

CODE

CR1018029

SCHEMA DI INSTALLAZIONE - INSTALLATION DIAGRAM - INSTALLATIONSPLAN - SCHÉMA D'INSTALLATION - ESQUEMA DE INSTALACION - INSTALLATIESCHEMA - IINSTALLATIONSRTNINGAR

MISURE IN mm - DIMENSIONS IN mm - ABMESSUNGEN IN mm
MESURES EN mm - MEDIDAS EN mm - MATEN IN mm

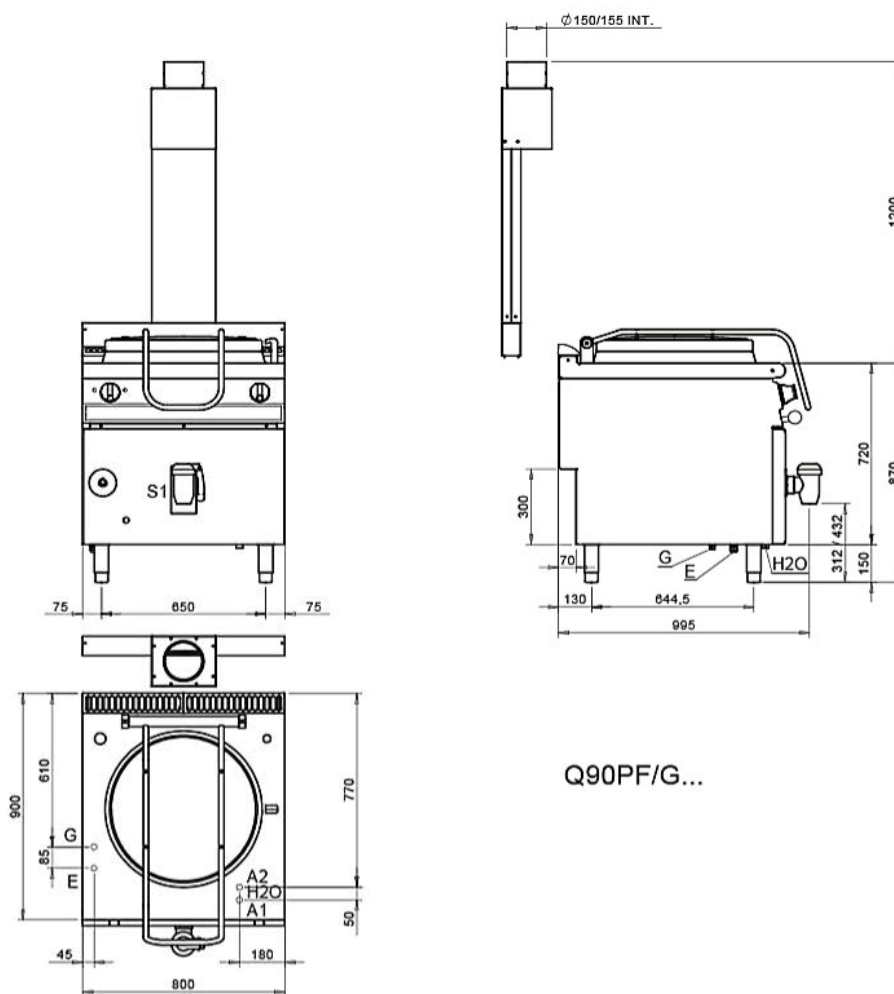

Q90PF/G...

Legenda - Legende - Key - Légende - Leyenda - Legenda

- H20 Attacchi arrivo acqua - Wasseranschluss - Water inlet - Arrivée eau - Union de agua - Wateraansluiting
- A1 = Calda - Heiss - Warm - Chaud - Caliente - Warm EN ISO 228-1 G 3/4
- A2 = Fredda - Kalt - Cold - Froid - Fria - Koude EN ISO 228-1 G 3/4
- E Pressacavo entrata linea elettrica - S opt/buchse - Electric cable stress relief Presse étoupe de câble él. - Elektrische kabelwartel
- G Attacco arrivo gas - Gasanschluss - Gas connection - Arrivée gaz - Union de gas - Gas aansluiting EN10226-1 R 1/2; EN ISO 228-1 G 1/2 (DK)
- S1 Scarico acqua - Wasserablauf - Water outlet - Vidange de l'eau - Desaguadero - Wateraansluiting 2'