

Glass Door Display

GDM-23F-HC~TSL01

 Upright Retail Merchandiser Freezer, 1 Full Glass Swing Door



Dimensions		Build		Technical	
External Width (mm)	686	Door Description	1 Full Glass Swing Door	Temperature Holding	-23°C
External Depth (mm)	759	Door Opening	Right (standard) or Left.	Refrigerant	R290
External Height (mm)	1998	Exterior Construction	Black powder coated Stainless Steel front, matching Aluminium sides and rear	Voltage / Frequency / Phase	220-240V/50Hz/1
Exclusions	Depth does not include 42 mm for door handle or 13 mm for rear access panel.	Interior Construction	White coated aluminium, stainless steel base	Amps	3.1
Net Volume (Litres)	445	Air Intake Position	Front	60Hz model Amps	2.8
Gross Volume (Litres)	651	Ventilation Position	Rear	Wattage	713
Display Area (m ²)	0.75	Clearance Required	26 mm rear, zero sides	60Hz model Wattage	644
Supplied Shelves	4	Cord Length (Meters)	2.74	Temperature Class	L1
Shelf Size (L x D mm)	574 x 591	Internal Lighting	LED	Operating Statement	Tested at 25°C, 60% RH, per 'Refrigerators with a Direct Sales Function' for perishable food merchandising.
Internal Net Height (mm)	1300	Standard w/ Locks	Not Standard. Options available.	Testing Standard	EN 23953
Unpackaged Weight (kg)	151			EEC	C
Packaged Weight (kg)	162			EEl	26.8
Packaged Dimensions (W x D x H mm)	902 x 775 x 2134			kWh/24hr	6.45
Supplied Supports	Leg Levellers (Castors supplied separate)			kWh/Annum	2355
				Defrost Type	Auto



Specifications subject to change without notice.
 Technical data above related to energy use based on testing of 50Hz or Dual Frequency models
 Chart dimensions rounded up to the next whole millimeter (inches rounded up to the 1/8")

UK & Ireland [0800 783 2049](tel:08007832049)
 EMEA [+41 61 563 07 05](tel:+41615630705)
 Australia [+61 2 9619 9999](tel:+61296199999)

TFIUK@truemfg.com
TrueCHCustomerService@truemfg.com
TrueRefAus@truemfg.com



GDM-23F-HC~TSL01

Upright Retail Merchandiser Freezer, 1 Full Glass Swing Door

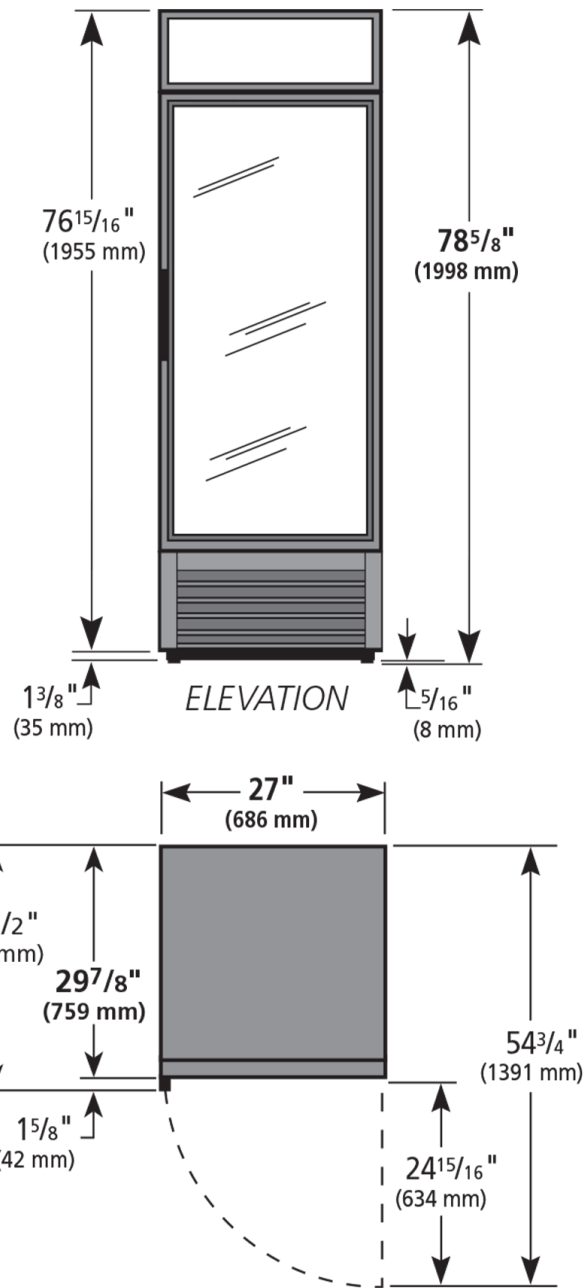

Specifications subject to change without notice.
Technical data above related to energy use based on testing of 50Hz or Dual Frequency models
Chart dimensions rounded up to the next whole millimeter (inches rounded up to the 1/8")

UK & Ireland 0800 783 2049
EMEA +41 61 563 07 05
Australia +61 2 9619 9999

TFIUK@truemfg.com
TrueCHCustomerService@truemfg.com
TrueRefAus@truemfg.com

