

SELF LEVELLING PLATE DISPENSERS

LAKESIDE have been designing and manufacturing dispensing equipment for over 60 years and are recognised as leaders throughout the world for high quality commercial grade equipment that withstands the rigours of commercial kitchens and venues.

Manufactured from high quality stainless steel, Lakeside plate dispensers are the choice of quality and reliability in plate dispensing solutions.

Available in a range of plate sizes in heated and non-heated models.

The dispensing level is easily adjusted by attaching or detaching springs. No tools are required.

High-strength stainless steel frame and the Easy-Glide™ design provides quiet, non-stick operation.

Heated dispensers feature shielded insulation and thermostatic control with thermostat minimum 38°C and maximum 79°C.

Dispensers have a 635mm stacking height capacity for an approximate capacity 65 plates.

The special 1944 'Adjust A Fit' heated model offers the widest range of plate sizes to suit the varying needs of any kitchen/serving situation.

UNHEATED PLATE DISPENSERS

CODE	DESCRIPTION	PLATE SIZES
4011	Open Model Drop-In	250-279mm
4012	Open Model Drop-In	280-311mm



MODEL 4011

HEATED PLATE DISPENSERS

CODE	DESCRIPTION	PLATE SIZES
6011	Shielded Drop-In 250-279mm	300 watts
6012	Shielded Drop-In 280-311mm	300 watts
1944	Adjust A Fit® Drop-In 254-337mm	450 watts



MODEL 6012



MODEL 1944

All heated dispenser models come with cord and 10A plug.

LAKESIDE[®]

specifications

Drop-in Dispensers

Open, Shielded and Heated

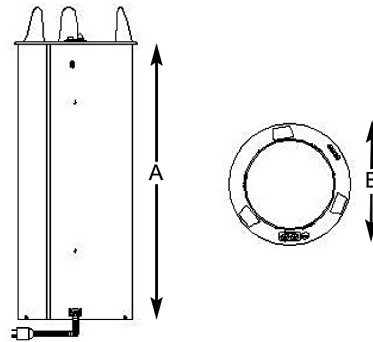

Dimensions

Model	Accommodates Plate Size	Height To Ring (A)	Top Ring Diameter (B)	Counter Cut-Out	Watts	(kg.)
Open Models						
4000	Up to (127) mm	(705) mm	(210) mm	(189) mm	–	(4.5)
4005	(130 to 146)	(705)	(229)	(208)	–	(4.9)
4006	(149 to 165)	(705)	(248)	(227)	–	(5.4)
4007	(168 to 184)	(705)	(267)	(246)	–	(5.4)
4008	(200 to 206)	(705)	(289)	(268)	–	(5.4)
4009	(210 to 232)	(705)	(314)	(294)	–	(6.8)
4010	(235 to 257)	(705)	(340)	(319)	–	(7.3)
4011	(260 to 279)	(705)	(356)	(344)	–	(7.7)
4012	(260 to 311)	(705)	(403)	(373)	–	(8.2)
Shielded Models						
5000	Up to (127)	(711)	(210)	(189)	–	(6.8)
5005	(130 to 146)	(711)	(229)	(208)	–	(7.3)
5006	(149 to 165)	(711)	(248)	(227)	–	(7.7)
5007	(168 to 184)	(711)	(267)	(246)	–	(8.2)
5008	(200 to 206)	(711)	(289)	(268)	–	(9.1)
5009	(210 to 232)	(711)	(314)	(294)	–	(10.4)
5010	(235 to 257)	(711)	(340)	(319)	–	(10.9)
5011	(260 to 279)	(711)	(356)	(344)	–	(11.8)
5012	(260 to 311)	(711)	(403)	(373)	–	(13.2)
Heated Models						
6000	Up to (127)	(711)	(210)	(189)	300	(8.2)
6005	(130 to 146)	(711)	(229)	(208)	300	(8.6)
6006	(149 to 165)	(711)	(248)	(227)	300	(9.1)
6007	(168 to 184)	(711)	(267)	(246)	300	(9.5)
6008	(200 to 206)	(711)	(289)	(268)	300	(10.4)
6009	(210 to 232)	(711)	(314)	(294)	450	(11.8)
6010	(235 to 257)	(711)	(340)	(319)	450	(12.7)
6011	(260 to 279)	(711)	(356)	(344)	450	(13.6)
6012	(260 to 311)	(711)	(403)	(373)	450	(14.5)

Measurements in () denote metric millimeters, unless otherwise specified.

Model	Adjusts to Fit Plate Size	Height to Ring (A)	Diameter (B)	Counter Cut Out Size	Wattage	Shipping Weight	
	Millimeters (mm)	mm	mm	mm		lb.	kg.
1944	254 to 337	711	432	413	450	35	15.9

Due to our policy of continuous product development, all specifications are subject to change without notice.

FSM (FOOD SERVICE MACHINERY PTY. LTD.)
HEAD OFFICE: UNIT E6, 63-85 TURNER STREET,
 PORT MELBOURNE, VIC. 3207 AUSTRALIA
 T: +61 3 8645 2555 F: +61 3 8645 2565
 E: sales@fsm-pl.com.au W: www.fsm-pl.com.au

SYDNEY OFFICE:
 UNIT 26, 7-9 PERCY STREET,
 AUBURN, NSW 2144 AUSTRALIA
 T: +61 2 8737 4666 F: +61 2 8737 4646
 E: sales@fsm-pl.com.au W: www.fsm-pl.com.au

QUEENSLAND:
 T: 0400 099 992
 E: sales@fsm-pl.com.au
 W: www.fsm-pl.com.au