

## HIGH-SPEED ACCELERATED COOKING OVENS

### High-Speed | Combi Cooking

10 times faster than a conventional oven



Model: SCIQ2

#### PERFORMANCE

The Bonn SpeediChef high-speed accelerated cooking oven utilizes a combination of forced convection, high speed tuned impinged air, top launched microwave to shorten the cook times significantly. It can bake, roast, toast, brown, and crisp foods up to 10 times faster than conventional methods while cooking evenly and consistently.

#### EXTERIOR CONSTRUCTION

- Exterior 430 stainless steel.
- Cool-to-touch exterior.
- Adjustable legs.

#### INTERIOR CONSTRUCTION

- Interior 304 stainless steel.
- Insulated cook chamber.
- Removable metal rack and bottom jetplate.



Fully programmable touchscreen controls

### High speed with less noise

Quiet – AVG 48 dB in standby mode

Uses less energy AVG 2.0kw/h

#### STANDARD FEATURES

- Touch mode interface with smart menu system, controls are intuitive and simple to use.
- Three “Set TEMP” modes to meet different temperature requirement.
- Temperature setting: 0-280°C.
- Total 432 recipes with multi-stage programming (Up to 6 stages for each recipe).
- Variable-speed, vertically-recirculated air convection and impingement, can heat, brown, and crisp powerfully and intelligently with low noise.
- Stirrer to help ensure even distribution of air and microwave.
- Edit recipe and image on both oven and PC
- USB port to load recipes and photos
- Built-in catalytic converter breaks down grease-laden vapors, allowing for ventless operation.
- Allows the use of the metal trays, pans, screens, simplifies cooking.
- Built-in self-diagnostics.
- Infra-red elements tilt-up for cleaning
- Warranty: 13 months parts and labour (onsite).

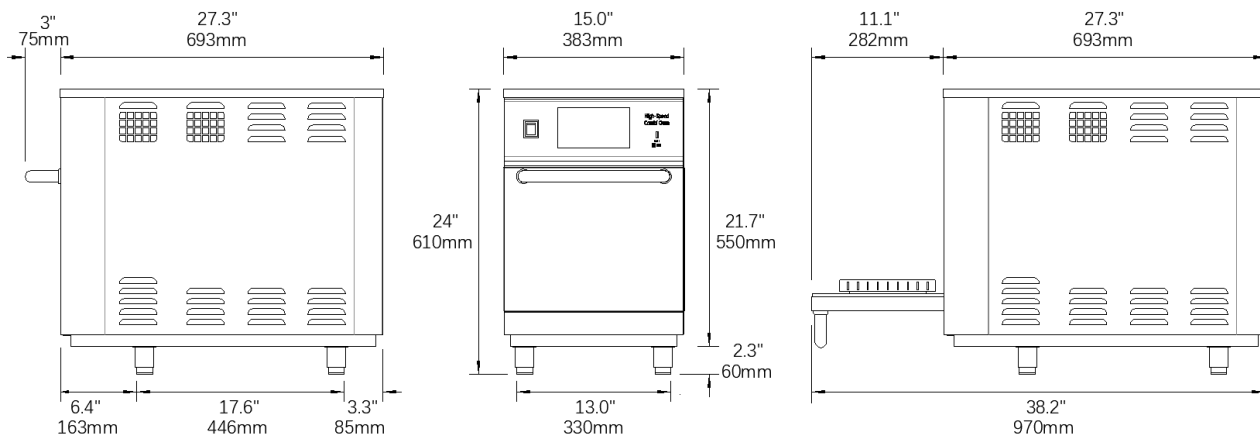

## DIMENSIONS

Overall	
Width	383 mm
Depth	693 mm
Height	610 mm
Weight	66kg
Length of power cord supplied	Approx. 2.5m
Chamber	
Width	320 mm
Depth	320 mm
Height	195 mm
Packed Dimensions	
Width	446 mm
Depth	866 mm
Height	756 mm

## SPECIFICATIONS

Function Type	
100% Microwave	1-Mag/ 1100w
Impingement	1-heater/1600w
Combi mode	1100w+1600w
Max Power	3500w
Max Current	15AMP
Power Source	Single Phase 208-250VAC, 15AMP
Frequency	2450MHz
Configuration	Countertop
Display	Touch display

