

Single pan automatic pasta cooker direct gas heating



BROTHS
RICE
PASTA
FISH
MEAT
EGGS
VEGETABLES
LEGUMES

PASTA MACHINES FOR LARGE-SCALE CATERING

This range of machines for large-scale catering consists of 21 models, with one or two tanks, from 120 to 240 litres, all equipped with individual baskets. The flexibility of the MULTICOOKER pasta cooker facilitates the traditional cooking of pasta in water ensuring speed and safety of working cycles, constant product quality and the best use of human resources.

FLEXIBLE AND FUNCTIONAL COOKERS FOR RESTAURANTS

The flexibility of the Multicooker automatic pasta machine allows it to be used for a large part of the traditional systems of cooking in water: the cooking of pasta, rice, soups, white and red meat, vegetables, etc.

Heating type	direct gas
Capacity (L)	188
Surface (dmq)	-
Gas connection (Ø)	3/4"
Electric connection (V/-/Hz)	1N+PE AC 230V 50Hz

Width (mm)	1000
Depth (mm)	900
Height (mm)	900
Gas power (Mj/hr)	129.6
Electric power (kW)	0.4

boiling | braising | pasteurising | **tilting** | mixing | cooling | frying | underpressure | vacuum cooking | cutting | washing | drying

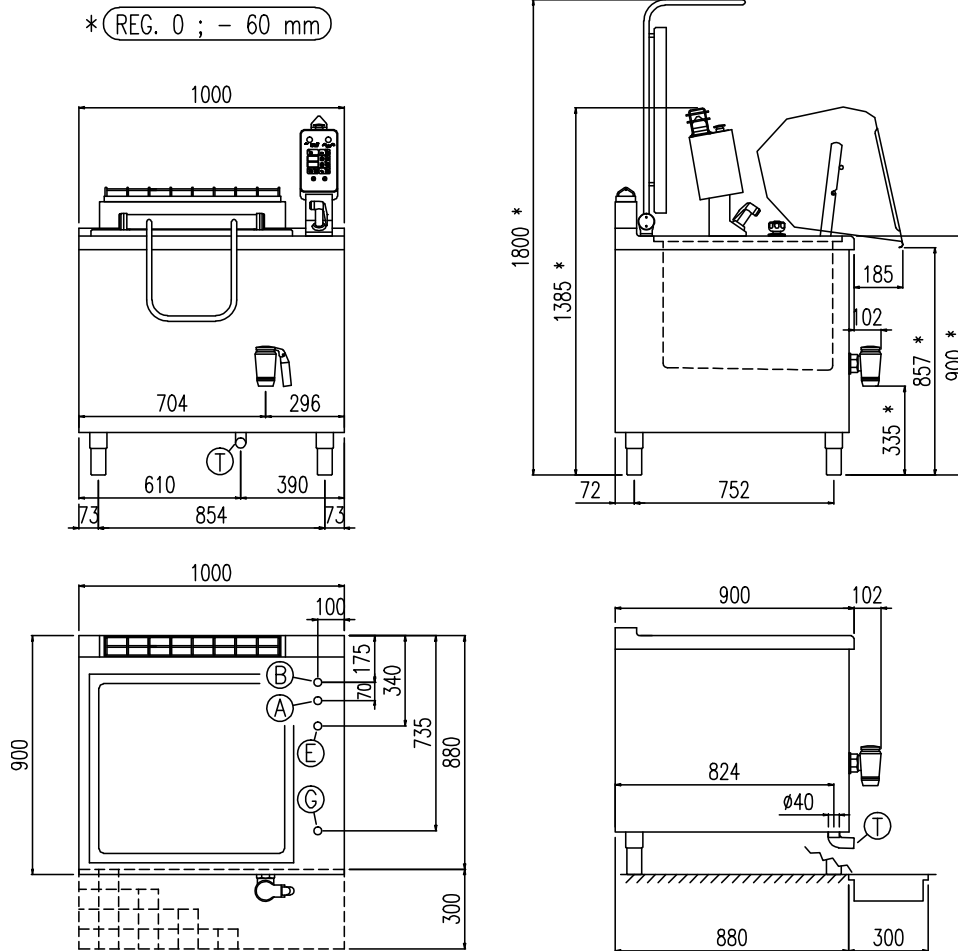

G	Attacco Gas (secondo ISO 7-1) Gas Connection (ISO 7-1)	Gasanschluss (ISO 7-1) Raccordement Gaz (ISO 7-1)	3/4"
E	Potenza assorbita Electric power	Elektrische Leistung Puissance Électrique	.40 (kW)
E	Collegamento Elettrico Electric connection	Elektrische Verbindung Connexion Électrique	220-240V 1N ~ 50Hz
A	Allacciamento Acqua Calda Hot water inlet	Warmwasseranschluss Raccordement eau chaude	1/2"

boiling | braising | pasteurising | **tilting** | mixing | cooling | frying | underpressure | vacuum cooking | cutting | washing | drying