

Double pan automatic pasta cooker direct electric heating



BROTHS
RICE
PASTA
FISH
MEAT
EGGS
VEGETABLES
LEGUMES

PASTA MACHINES FOR LARGE-SCALE CATERING

This range of machines for large-scale catering consists of 21 models, with one or two tanks, from 120 to 240 litres, all equipped with individual baskets. The flexibility of the MULTICOOKER pasta cooker facilitates the traditional cooking of pasta in water ensuring speed and safety of working cycles, constant product quality and the best use of human resources.

FLEXIBLE AND FUNCTIONAL COOKERS FOR RESTAURANTS

The flexibility of the Multicooker automatic pasta machine allows it to be used for a large part of the traditional systems of cooking in water: the cooking of pasta, rice, soups, white and red meat, vegetables, etc.

Heating type	direct electric
Capacity (L)	135 + 135
Surface (dmq)	-
Gas connection (Ø)	-
Electric connection (V/-/Hz)	3N+PE AC 400V 50/60 Hz

Width (mm)	1600
Depth (mm)	900
Height (mm)	900
Gas power (Mj/hr)	-
Electric power (kW)	17 + 17

boiling | braising | pasteurising | **tilting** | mixing | cooling | frying | underpressure | vacuum cooking | cutting | washing | drying

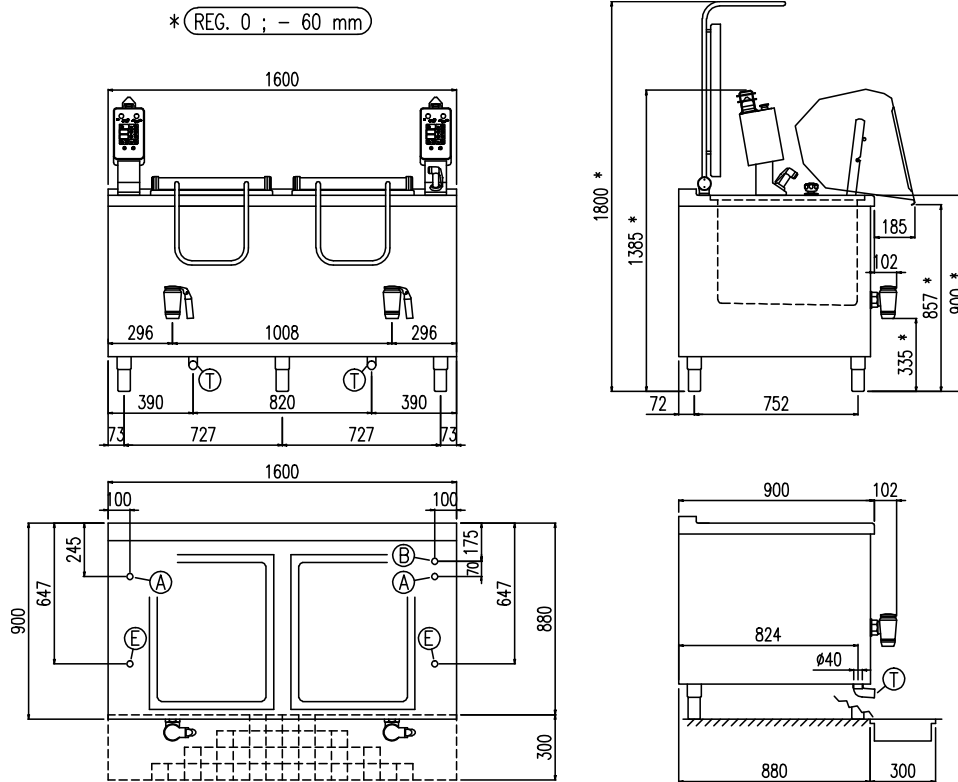

E	Potenza assorbita Electric power	Elektrische Leistung Puissance Électrique	17.00 (kW)
E	Collegamento Elettrico Electric connection	Elektrische Verbindung Connexion Électrique	380-415V 3N ~ 50/60Hz
A	Allacciamento Acqua Calda Hot water inlet	Warmwasseranschluss Raccordement eau chaude	1/2"

boiling | braising | pasteurising | **tilting** | mixing | cooling | frying | underpressure | vacuum cooking | cutting | washing | drying