

# EASYBRATT

medium line



## EasyBratt | Tilting Bratt Pans

EASYBRATT is a tilting braising pan designed to meet the daily needs of small and medium-sized restaurants, the catering industry and centralised cooking facilities (canteens, community centres, schools, hospitals, etc.). Available in gas or electric heating, the tilting is manually operated, but can be motorised on request.

## Multipurpose equipment for a truly professional kitchen

Among the catering equipment developed by Firex, Easybratt is definitely one of the simplest and quickest to learn to use, since it has been designed specifically to meet the needs of small cooking centres. It is a professional bratt pan developed to braise different types of food: chicken, risotto, omelettes, stew, etc.

## DIRECT ELECTRIC HEATING

MODEL	CAPACITY lt	POWER kW	DIMENSIONS mm	SURFACE dmq	BOTTOM TYPE	
BM 1 E 160 l	162	24.8	1600 x 900 x 900H	85	AISI 304	15 mm
BM 1 E 200 l	205	24.8	1600 x 900 x 950H	85	AISI 304	15 mm
BAS0041		Motorised tilting				



## Easybratt can be used for

- Chicken
- Escalopes
- Stew
- Spare ribs
- Meat balls
- Omelette
- Mirepoix
- Risottos

**boiling** | **braising** | pasteurising | tilting | mixing | cooling | frying | underpressure | vacuum cooking | cutting | washing | drying

# EASYBRATT

medium line

TECHNICAL DRAWING MOD. **BM 1 E 160 L**

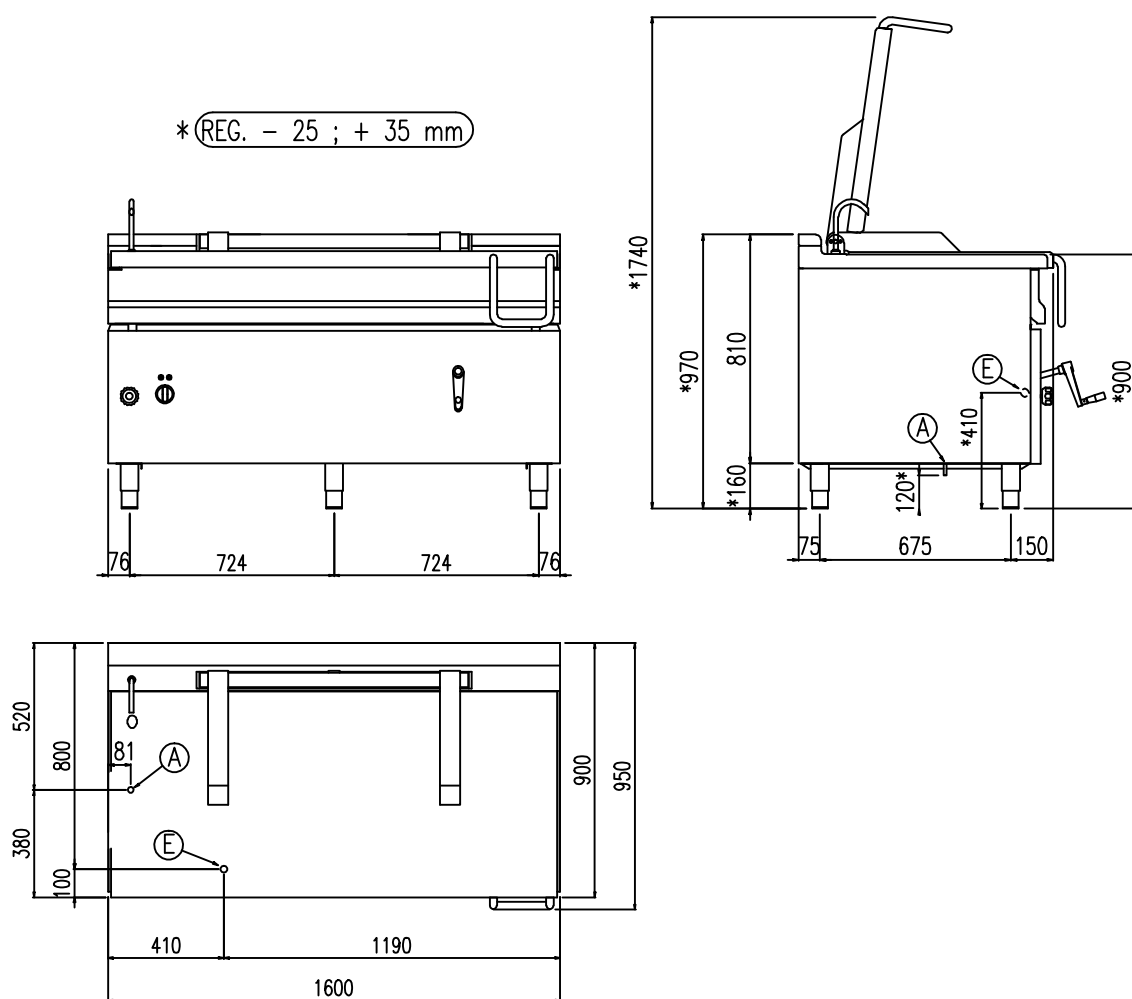

# EASYBRATT

medium line

TECHNICAL DRAWING MOD. BM 1 E 200 L

